

Boston Centers for Youth & Families Programming & Siting Study Charlestown

CITY of BOSTON | *Mayor Michelle Wu*

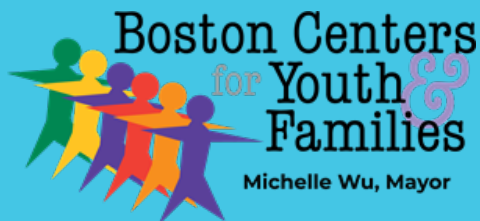

Table of Contents

Executive Summary

1 Process 7

- 1.1 Project team
- 1.2 Study Phase Schedule
- 1.3 Project schedule

2 Existing Conditions 13

- 2.1 Condition Analysis
- 2.2 Demographic Analysis

3 Engagement & Data 19

- 3.1 Engagement Process
- 3.2 Program Study
- 3.3 Siting Study

4 Programming 29

- 4.1 Program Metrics
- 4.2 Room Sheets
- 4.3 Net Zero Carbon Goals

5 Site Options and Test-Fits 73

- 5.1 Identification of Suitable Sites
- 5.2 Selected for Test-Fits
- 5.3 Test-Fit Sites in Detail

Appendix A 105

- A.1 Potential Sites: Complete List
- A.2 Building Systems Narratives
- A.3 Test fits: Cost Estimates
- A.4 Reference: Devine Rink Test-fit Cost Estimate

Appendix B - Public Engagement 177

- B.1 Public Survey
- B.2 Public Comments
- B.3 Public Meeting Presentations

Executive Summary

In 2020 the City of Boston's Public Facilities Department engaged Utile Inc. to work with Boston Centers for Youth and Families (BCYF) to study siting options and programming needs for new a BCYF Center in Charlestown. The study included a public engagement process that gathered public feedback on existing centers, programming goals, and potential sites. The study called upon a Community Advisory Committee (CAC) made up of community representatives to offer their personal insight on the process, and disseminate engagement tools amongst their neighborhood areas. The engagement process also involved several virtual community meetings, polls, and Q&A sessions, as well as an online survey.

Study Scope and Goals

The study included three major tasks: program recommendations that establish the types of uses and activities in a new BCYF center in Charlestown, site identification, and concept design test-fits of the BCYF center on the selected sites. Program recommendations are based on conversations with BCYF staff leadership and an analysis of existing programs offered by BCYF facilities, as well as community input on what programmatic elements are most necessary and desirable. Site recommendations are based on a spatial analysis of the neighborhood, community generated recommendations, and the square footage requirements of the desired BCYF programs.

Several key goals and objectives for a new center emerged out of meetings with BCYF staff and community members throughout

Charlestown. These include:

- **Stand-alone facility:** create a purpose built BCYF center that is not limited by hours or activities for mission-critical facilities.
- **More programming:** create adequate space for uses and activities geared to the neighborhood.
- **Flexibility:** provide flexible spaces for a range of activities and user groups.
- **Diverse Users:** serve the different interests and needs of BCYF's users including youth, teens, adults, families, and seniors.

Summary of Findings

The programming portion of the study revealed an overall need for more services throughout the neighborhood, as well as the limitations of the existing Boston Public Schools affiliated site in terms of access, spatial availability and operating hours. While a variety of program is desired across the spectrum, there is an especially strong desire for flexible spaces that can be utilized by a variety of occupants at a variety of times. Additionally, BCYF Charlestown is in particular need of their own indoor athletics and recreation facilities. They currently use the athletics and recreation facilities of Charlestown High School and are subject to the school's schedule and space constraints.

From the analysis phase, the team was able to identify roughly nine sites, from which two promising options were identified to perform three test fits with varying qualities of scale and proportion. These sites were chosen

using a variety of factors including: proximity to existing services, flood risk, transportation, land availability, land ownership, and feedback from the community and City of Boston Public Facilities Department and BCYF teams. From the three test fits presented, pros and cons were generated for each and two test fits; one on each site, were selected for a cost analysis study. One test fit presents shared use of athletics facilities with the adjacent Charlestown High School and the other a stand alone facility in the Navy Yard. The shared facility sits at the lower end of the cost spectrum, while the stand alone at the higher end.

Summary of Costs

The cost analysis for the two focus sites estimated a hard cost range of roughly \$36 million to \$62 million. Costs for equipment and furniture for a new BCYF center that includes all programs specified in the study were approximated at \$2.5 million, resulting in a hard cost range of \$39.2 million to \$64.7 million. The estimated total project cost using margins, adjustments and soft costs specific to City of Boston municipal projects will be prepared separately by the Public Facilities Department.

Please refer to the full estimate in Appendix A for a full breakdown of estimated hard costs.

Conclusion

The analysis and engagement results of the BCYF Charlestown study emphasize the need and community desire for a new BCYF facility in Charlestown. The study provides a catalog of program recommendations and siting options that can serve as a basis for developing and siting a new center that provides adequate space for BCYF programs, fits into their surroundings, and provides opportunities for new programs that reflect the diverse needs of the community.

page not used

Section 1

Process

1.1 Project Team

City of Boston

Michelle Wu, Mayor
Dion Irish, Chief of Operations
José Massó, Chief of Human Services

Boston Centers for Youth & Families

Team Role: Engage with the community, gather feedback for the larger team, and provide input on building uses and activities

Marta Rivera, Commissioner
Edward McGuire, Director of Operations
Sandy Holden, Public Information Manager
Mimi Wren, Charlestown Community Center Director
James Burke, Charlestown Community Center Program Supervisor
Kate Hennigan, Program Manager
Meaghan Murray, Senior Center Director
Daniel Monahan, Regional Operations Manager
Jeffrey Mackey, Aquatics Manager
Antonio Rosario, Aquatics manager

Public Facilities Department

Team Role: Provide data to the project team, coordinate with other city agencies, and direct the consultant team

Kerrie Griffin, Director
Elen McDonough, Chief of Staff
Evan Brinkman, Assistant Director for Design
Alistair Lucks, PM II for Studies

Office of Neighborhood Services

Sean Breen, Charlestown Liaison

BCYF Charlestown Community Advisory Committee

Team Role: Engage with neighbors to gather feedback on the study process, provide a consistent group to provide input from the beginning to the end of the study, and provide input to the project team on study priorities

Jesus Gambaro, BCYF Staff
Pete Washington, BCYF Staff
Alphy Vasquez, BCYF Teen Member
Jason Feinberg, BCYF Site Council Member
Natalie Mangrum, BCYF Member Parent
Eric Walsh, Charlestown Youth Basketball
Mswati Hanks, Charlestown Coalition
Peggy Bradley, Charlestown Neighborhood Council
Lana Tager, Charlestown Mothers Association
Kim Mahoney, Bunker Hill Associates

Consultant Team Utile Architecture & Planning

Team Role: Analyze and present data, develop a building and site program, test the program on specific sites, and prepare a final report summarizing the initial study process

Brett Bentson, Principal
Michael LeBlanc, Consulting Principal
Alessandro Ricciardi, Urban Designer
Andrew Ngure, Designer

1.2 Study Phase Schedule



Community Meeting 1

In the first meeting, the team established goals, presented BCYF program standards, and conducted an initial Zoom Poll as a jumping off point for community input on programmatic elements. The meeting was then opened up for Q&A. The online poll was also made live for continued community engagement throughout the study.

Community Meeting 2

In the second meeting, preliminary polling results were shown and explained. The team presented an initial program based on community input and talked through the process for selecting potential sites in Charlestown. The meeting was then opened up for Q&A.

Community Meeting 3

In the third meeting, updated results from the ongoing programming survey were shown and explained. A large selection of potential sites were presented and the meeting was then once again opened for Q&A.

Community Meeting 4

In the fourth and final meeting, the team summarized the study thus far, and once again went through the results of the programming survey as they neared their conclusion. The team also broke down the pros and cons of the existing test-fits, and explored the next steps of the study before opening the meeting up to a final Q&A for this phase.

1.3 Project Schedule



Study

The study phase, now reaching its conclusion, involved the utilization of several community meetings and online engagement tools to:

- Determine program uses
- Determine potential sites
- Test fit desired program on those sites
- Solicit continued community feedback throughout the process

Budgeting

The budgeting phase will typically last 6 - 12 months, and will involve consolidating the necessary funds for project implementation based on the results of the study process.

Land Acquisition

If necessary, the land acquisition process would typically take 6 - 12 months, and would involve varying levels of complexity depending on factors such as site ownership.

Design

The design phase will typically take 12 - 15 months, and will offer a second opportunity for community feedback and involvement in the project. This phase will conclude with a complete and formally documented design, ready for construction.

Construction

Once the design process is complete, the construction phase can begin, which would likely last 24 - 30 months (including a 3 month bidding process), and will conclude with a completed building.

Opening

Once construction is complete, the building can be outfitted with furniture and technology and opened to the public. This will typically occur between 4 and 6 years from the very beginning of the study process.

page not used

Section 2

Existing Conditions

2.1 Condition Analysis

Existing BCYF Analysis

BCYF Charlestown grapples with the challenge of finding adequate space for existing and new programs. The center is located in the Boston Public School's Charlestown High School which is ill-suited to support the added uses of a community center. While school sites can act as an easy site for the implementation of a community center due to programming similarities, school locations often have limited space, as well as limitations on BCYF operating hours.

There are currently three BCYF Centers located in Charlestown. These sites contain varying amounts and types of program depending on location. The current BCYF Charlestown is located on Charlestown High School property and offers art classes, community enrichment programs and more. It also offers athletics and aquatic programs at the gym and swimming pool which it shares with Charlestown High. The Clougherty pool (currently closed) includes an outdoor pool and changing facilities. The Golden Age Senior center is a stand-alone BCYF facility that features a kitchen and community rooms offering various senior programming. These sites are located adjacent to existing public transit ways however, they are either in need of increased capacity, more diversity of program, or both.

Outside of the three BCYF sites in Charlestown; Mirabella outdoor pool that is operational only during the summer months and BCYF Nazzaro in the North End are the most accessible to Charlestown residents.

BCYF Nazzaro is a stand-alone center featuring a fitness center, community room, teen center, senior center and a gymnasium. Charlestown also contains a variety of additional community services scattered throughout the neighborhood.

Demographic Analysis

The study included mapping demographics data from the 2015-2019 American Community Survey, and the MassGIS 2020 U.S. Census Dataset. Some of the data compiled and represented graphically include: population density, population by race, median household income, population over 65, and population under 18, as well as environmental data such as flood map projections.

Data mappings such as population density and household income can help identify census blocks under particular strain that a community center could help alleviate through programming. Age related mappings help to identify areas with higher concentrations of demographics who are the primary users of BCYF services. This data can also help determine what kind of program should be included in a center, whether it be a teen center, senior services, or both.

Environmental mappings can help determine what areas of the neighborhood may be most suited for long term development, or where additional planning is needed to ensure safety, resiliency, and longevity.

Existing BCYF Programs

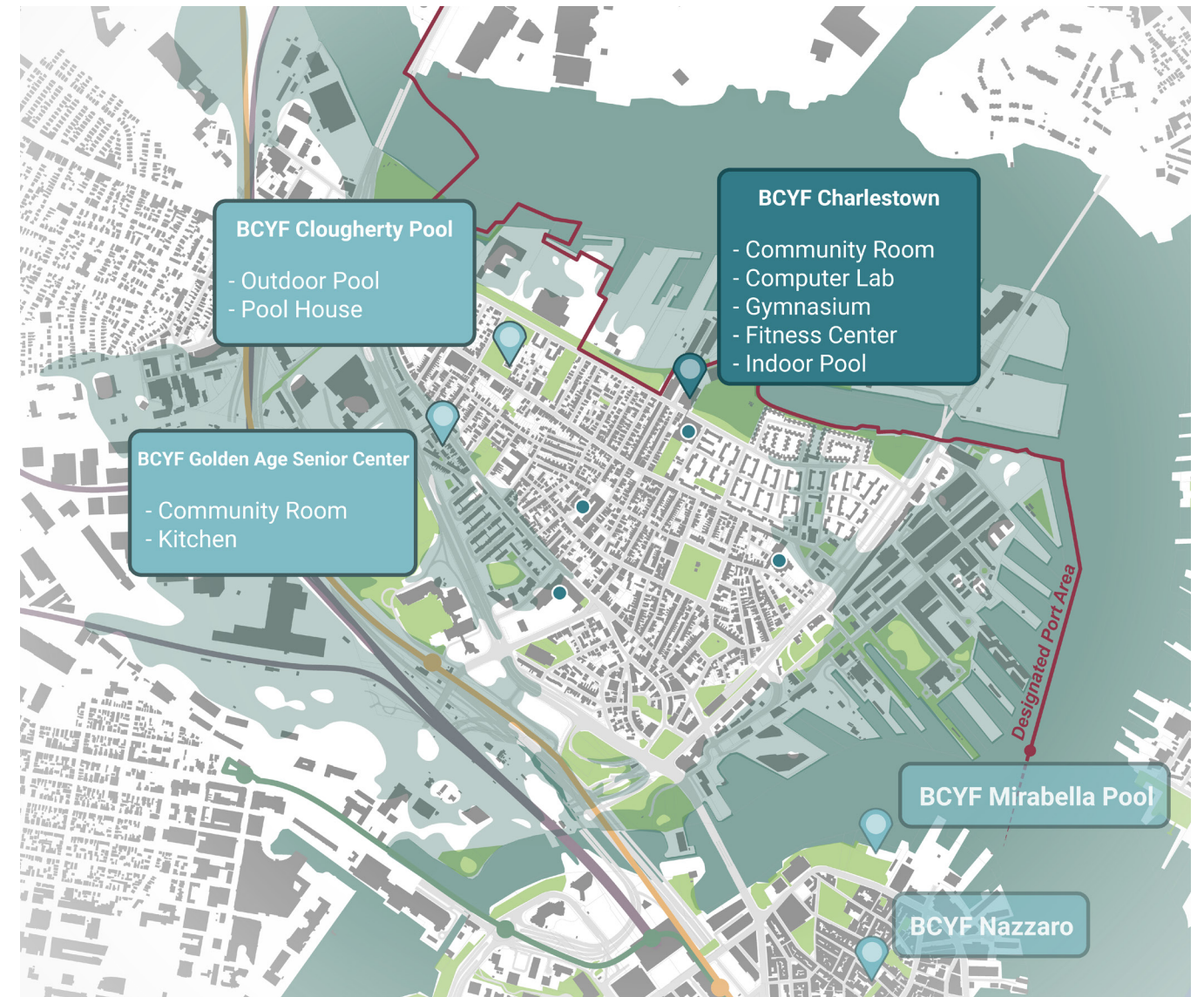

SITE KEY

- BCYF (BPS) [Blue location pin icon]
- BCYF (STAND-ALONE) [Light blue location pin icon]

2.2 Demographic Analysis



Source: MassGIS 2010 U.S. Census Dataset

Population mappings help the team better understand the diverse communities that make up Charlestown. Keeping the general locations of these communities in mind helps ensure that potential sites are being identified equitably and without exclusion.

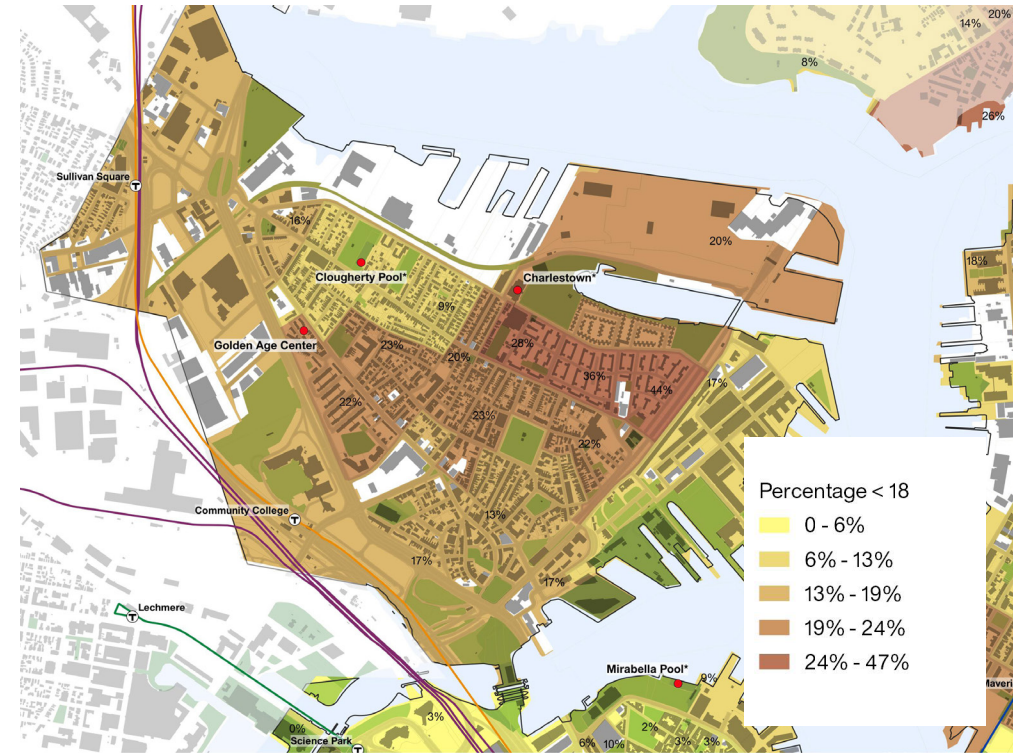

Source: MassGIS 2020 U.S. Census Dataset

The under 18 population is one of the primary users of BCYF services. This mappings helped the team better identify areas that could benefit from a new center and serve young BCYF users.

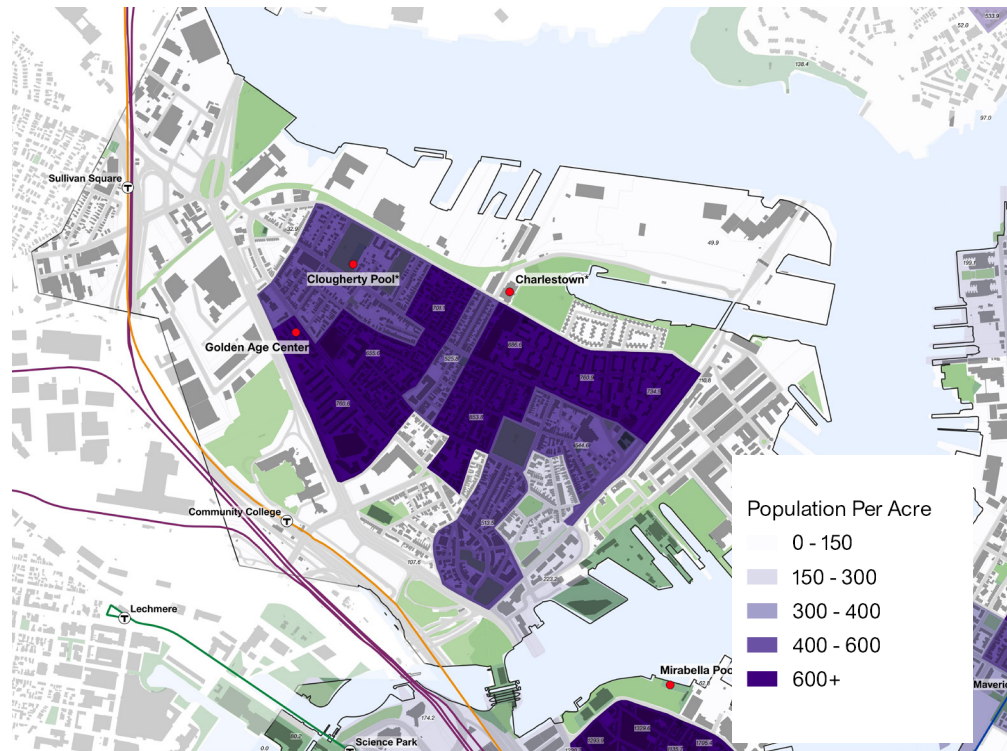

Source: MassGIS 2020 U.S. Census Dataset

Population density mappings were used to identify areas with the highest concentration of residents throughout Charlestown. This creates a strong starting point for locating sites with the highest demand and need for community and family services in the neighborhood.

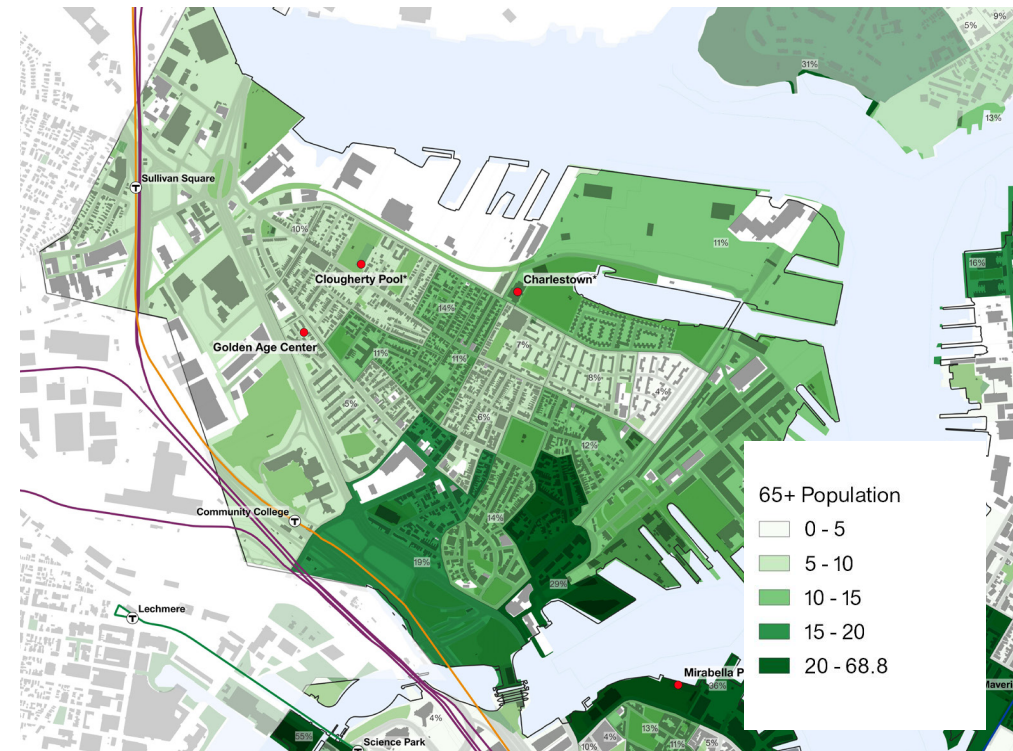

Source: MassGIS 2020 U.S. Census Dataset

Much like the under 18 mapping, the over 65 population mapping offers a more specific look at one of BCYF's target communities. Mappings like these inform the team of not only where older or younger populations may be in need of a new BCYF center, but also of what kind of programmatic elements may best suit the surrounding users.

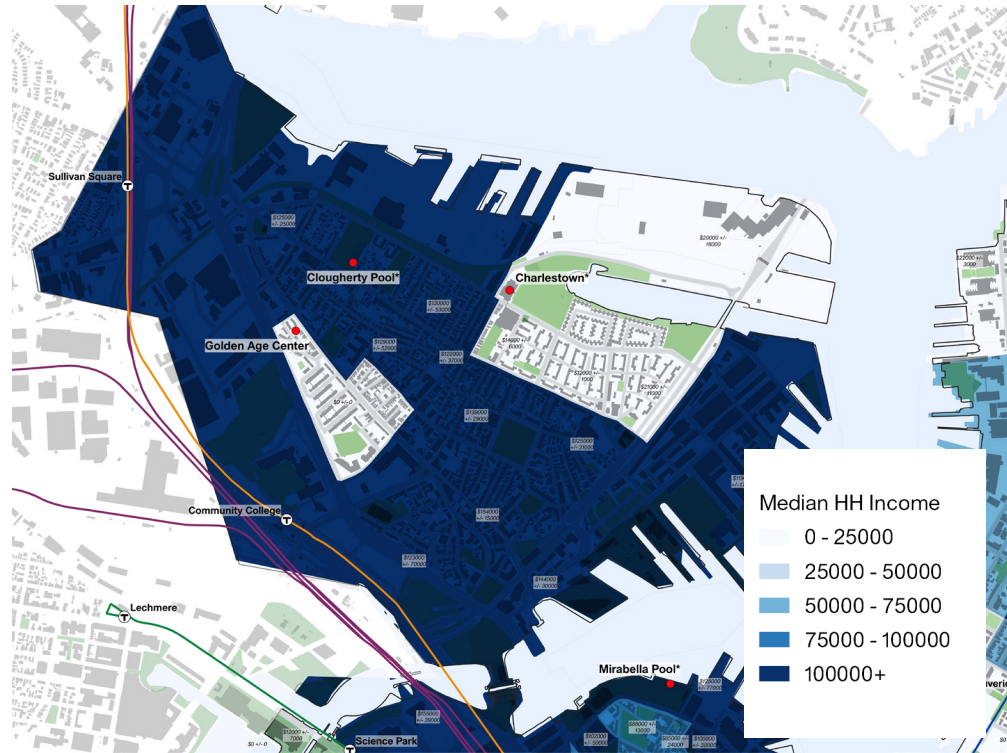

Source: MassGIS 2020 U.S. Census Dataset

Median household income mappings can also help identify pockets of Charlestown with the greatest need for a new BCYF center. To embrace the city's goal of ensuring access to a wide range of community programs and services for all, it's important to locate areas where families can benefit from public programming for youth and elders.

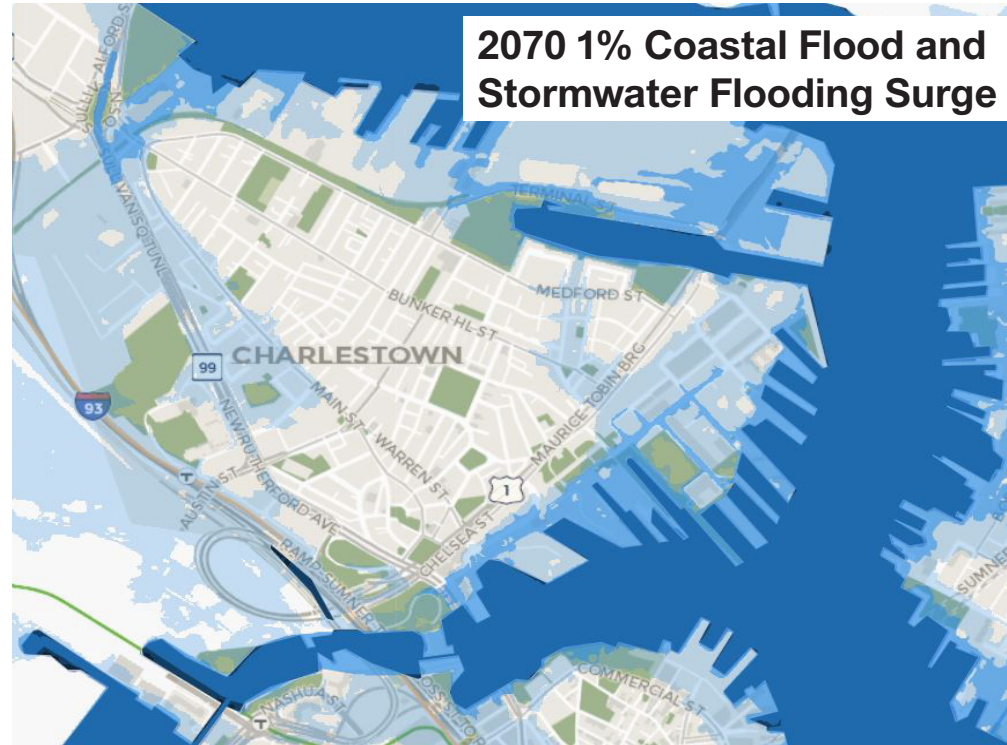

Source: Mass GIS Climate Ready Boston "1% Annual Coastal Flood Risk: 2070"

Flood projection mappings are extremely important to ensuring the development of resilient, future-proofed spaces. These analyses allow the team to find sites outside of the future flood risk zone, or otherwise create design solutions to mitigate risk of flooding on the site over time.

Section 3

Engagement & Data

3.1 Engagement Process

A variety of community engagement efforts were employed throughout the duration of the study in order to solicit comprehensive feedback from the Charlestown community.

The study began with an initial public Zoom meeting on November 16, 2020, in which general ideas were laid out, and the community was given the opportunity to offer early feedback. Members of the Charlestown community and local CAC were also asked to respond to live polls on what programming would be most desirable and necessary in accordance with BCYF standards. The online version of the survey was then opened up to the public and disseminated by BCYF staff and CAC members throughout the neighborhood. These public meetings were recorded and posted to the City of Boston website at the link listed below to promote transparency and continued engagement.

The survey first took note of respondent's place of residence, age, and whether they currently utilize any BCYF facilities. They were then asked to rank their choices of popular program options from a variety of categories.

In the refinement of program, the engagement feedback in the Community and Education category revealed a strong preference for youth rooms and classrooms as spaces that can be used for a variety of uses at different times. Some elements like teen rooms and senior centers can benefit from specialization and privacy, but given spatial or monetary constraints, flexibility is the priority. For the Arts category, performance spaces and art rooms were most popular. This again means that flexibility will be key in creating spaces that can be used for this purpose, without necessarily dedicating space to it.

In regards to Fitness, indoor pools were the most popular option, with fitness/dance studios and weight rooms also being popular. Fitness studios can be open, flexible spaces, which could have weight lifting equipment added to them should there be demand.

For gym spaces, basketball courts and indoor tracks dominated the results, with all other program able to flexibly fit within the gym if need be. Outdoor spaces favored athletics fields, basketball courts and an assembly space for social gathering.

Refer to Appendix B.1 and B.2 for a complete copy of the Survey and Survey results.

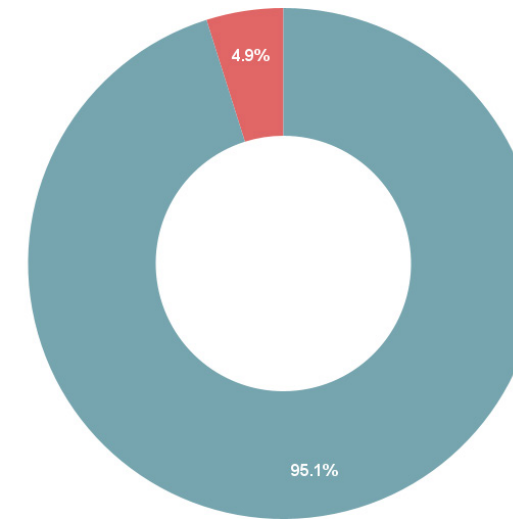

Respondent Charlestown Residency

- Yes
- No

Total responses: 431

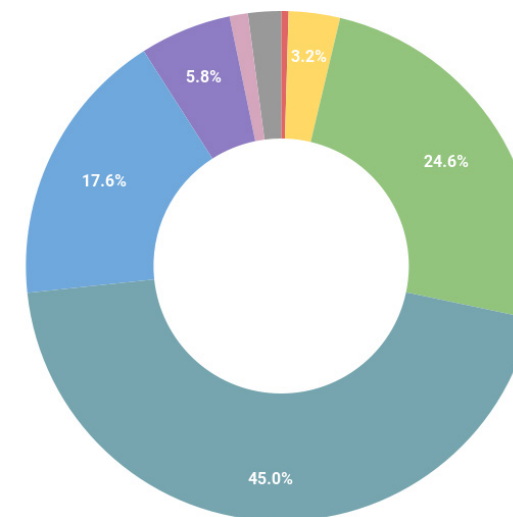

Respondent Ages

- <20
- 20-29
- 30-39
- 40-49
- 50-59
- 60-69
- >70
- N/A

Total responses: 431

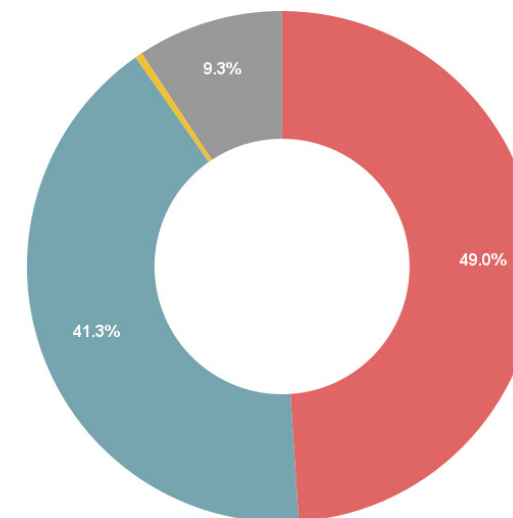

Respondent BCYF Usage

- BCYF Charlestown
- Clougherty Pool
- Golden Age Senior Center
- None of the Above

Total responses: 431

Meeting recordings: <https://www.boston.gov/departments/boston-centers-youth-families/bcyf-charlestown>

3.2 Program Survey

Aside from which typical BCYF program residents would most like to see, the survey also invited participants to generate ideas for other program types they would like to see in new centers. These ideas ranged from continuing education courses, to daycare services, to community gardens. These responses will be very useful for looking at how BCYF and its programmatic elements may evolve over time to best suit the diverse needs of their users.

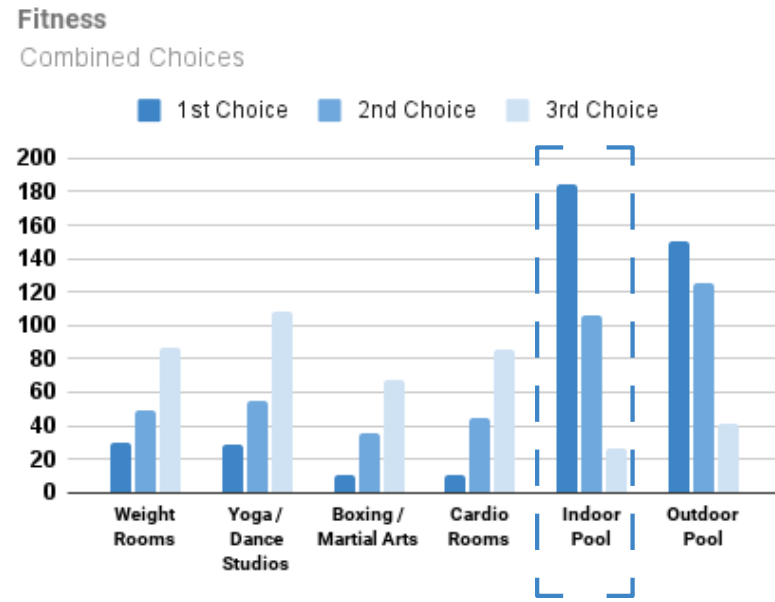

An indoor pool was the most popular choice, followed by an outdoor pool and yoga/dance studios. The indoor pool has been incorporated into the "ideal program" metrics while the other desired programs such as yoga / dance studios and weight rooms have been incorporated into a flexible Fitness Studio that can be further defined as design progresses at each community center.

Total responses: 431

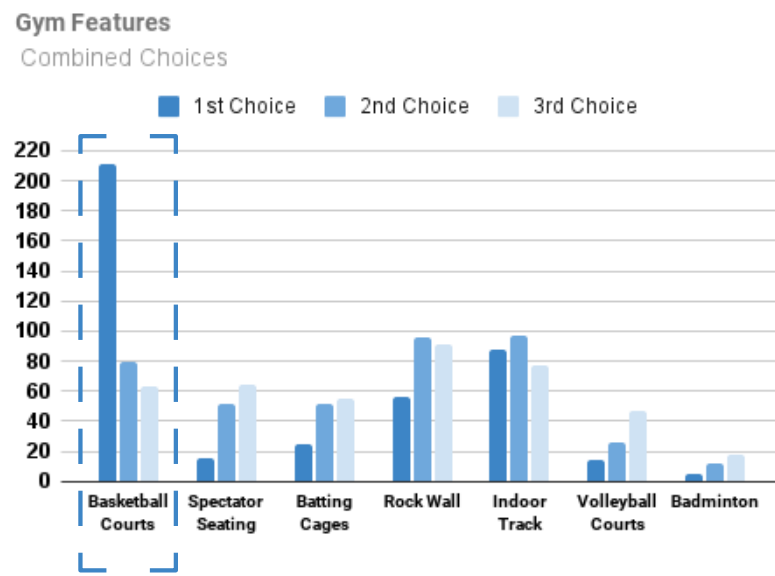

Basketball courts were most popular by a substantial margin, followed by both an Indoor track and Rock/Climbing wall. The Indoor track has fixed spatial requirements which are included in the Gyms of all program metrics. The Climbing wall could be incorporated into the Gym space.

Total responses: 431

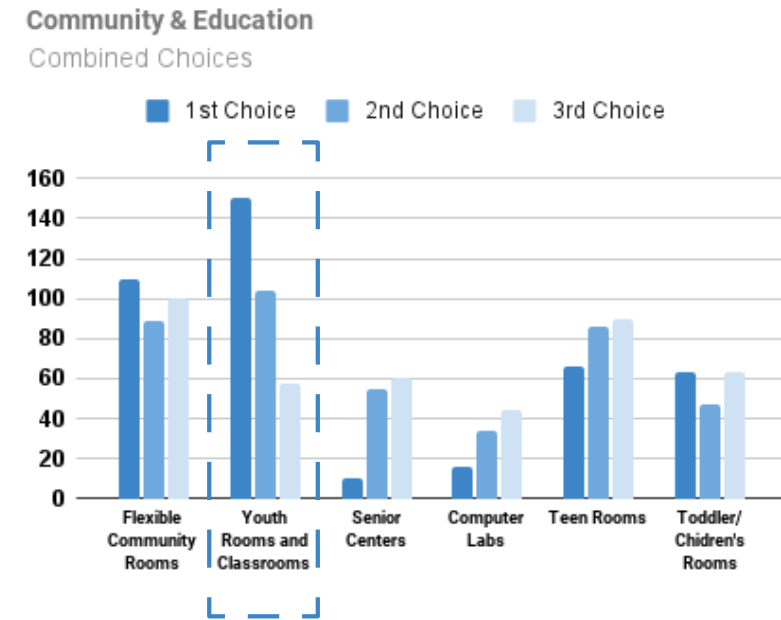

Youth Rooms and Classrooms were the most popular 1st and 2nd choice Community and Education programs. There is also a strong desire for Flexible Community rooms to cater to the varying spatial demands of the community as evidenced by the dispersed demand among the remaining programs. This flex space would be a large partitionable space, attached storage spaces and a separate restroom.

Total responses: 431

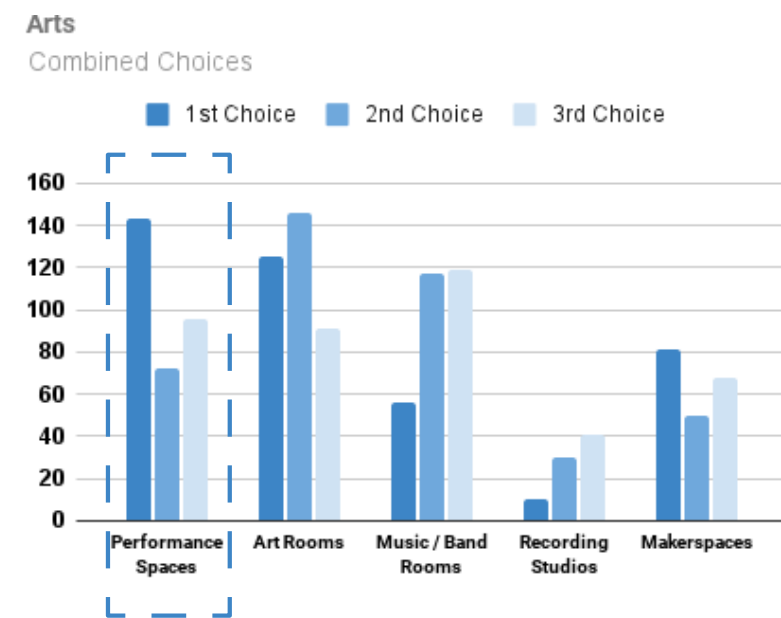

The poll showed a strong demand for adaptable performance spaces capable of catering to varied specialized performances. The need for flexibility in spaces carries through to the Art and Music programs. They will be spaces with equipment and plenty of storage to support many types of activities. To maximize flexibility, the Community Room should include acoustics, lighting, and audio/video capabilities to support a range of performances in a flat-floor space.

Total responses: 431

Outdoor Spaces Combined Choices

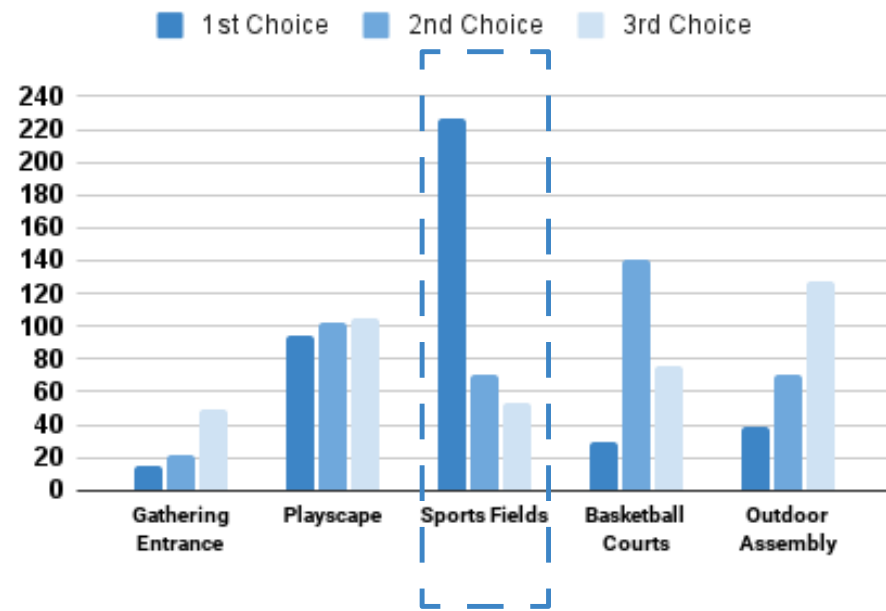

Total responses: 431

Survey responses showed greatest interest in Sports Fields, Basketball Courts and Assembly spaces at building entries. Playscapes and gathering spaces at entries are already included in the ideal BCYF program. Adjacency to athletic fields is an important attribute in identifying a suitable site location.

Typical BCYF Programming

Community & Education	Arts	Fitness & Sports	Outdoor Spaces
Community rooms	Performance spaces	Yoga/dance studios	Gathering entrances
Classrooms	Art rooms	Weight & cardio rooms	Playscapes
Toddler/childrens' rooms	Music/band rooms	Pools	Outdoor courts
Senior centers	Recording studios	Gyms	Outdoor assembly spaces
Teen centers	Makerspaces	Basketball courts	Sport fields
Computer labs		Batting cages	
		Rock walls	

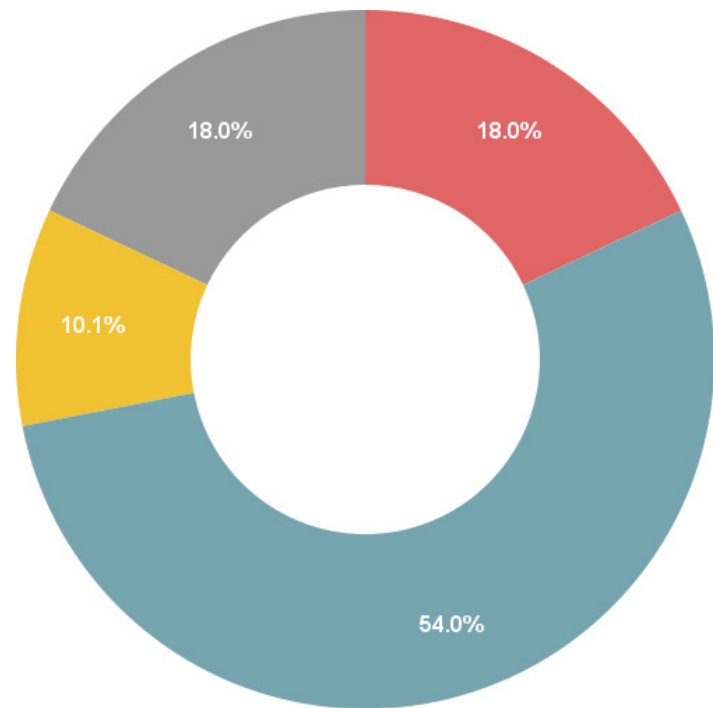

Total responses: 139

What kind of performance space works best?

Survey responses showed greatest desire for a large flexible multifunctional space capable of hosting performances, large community gatherings and social programs.

- A medium sized flexible space (a multipurpose space like a community room)
- A large flexible space (a large multipurpose space big enough for a stage and performances)
- A more specialized space (a large space with built in seating like a theatre)
- None of the above. Having a performance arts space is not important to me

3.3 Siting Study



The online survey gave us a clear understanding of user demographics and desired programmatic elements. It also provided the community the opportunity to communicate their needs and wants as well as provide general feedback.

In addition to the demographic and flood risk mapping described in Section 2, certain areas of Charlestown are located within a Designated Port Area. Land within this designated area requires state legislature approval for non-maritime uses.

Refer to Appendix B.2 for a complete list of comments

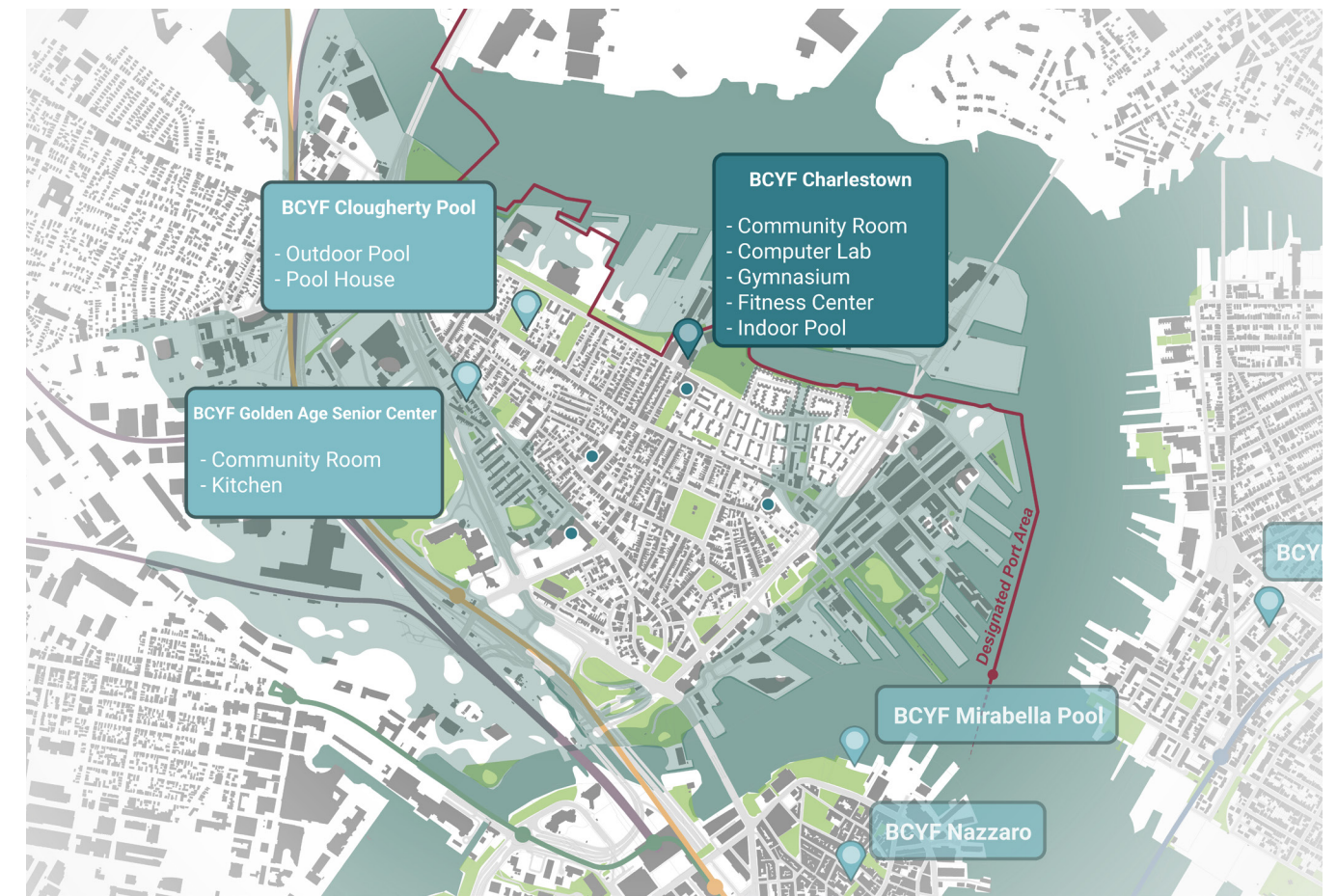

page not used

Section 4

Programming

4.1 Program Metrics

	Min. SF	Occupancy Max	Quantity	Total SF
Entry Lobby				
Vestibule	80	16	1	80
Reception Desk	100	2	1	100
Lobby	600	120	1	600
Storage	80	1	1	80
Vending	40	-	1	40
Entry Lobby NSF				900
Operations				
Office	340	7	2	680
Janitor	120	1	1	120
Trash/Recycling room	100	1	1	100
Outdoor maintenance storage	100	1	1	100
Storage	250	1	1	250
Mechanical / Tel-Data	1,500	1	1	1,500
Restroom/Storage	600	-	2	1,200
Laundry Room	80	2	1	80
Operationsl NSF				4,030
Community and Education				
Teen center	1,600	80	1	1,600
Youth classroom	1,000	50	1	1,000
Youth flex room	1,200	34	1	1,200
Tech Lab	1,000	30	1	1,000
Makerspace	1,000	30	1	1,000
Senior center	1,000	50	1	1,000
Community room	1,600	80	1	1,600
Community Kitchen	600	20	1	600
Community and Educational NSF				9,000
Arts				
Art room	900	45	1	900
Arts NSF				900

The program is broken into groupings of spaces that reflect the operations of the building and the general categories of uses and activities in BCYF Community Centers. The program spaces reflect net square footage requirements, and a "grossing factor" representing 70% efficiency has been added to allow for corridors, elevators, and wall thickness. As design at individual community centers and specific sites continues, this grossing factor may increase or decrease depending on the particular constraints of the project.

This program reflects both the operational needs and goals of BCYF and the priorities identified by the Charlestown community in

	Min. SF	Occupancy Max	Quantity	Total SF
Indoor sports and fitness				
Gym				-
Single court	7,280			
Double court	13,780			
Double + Multi court	16,510			-
Gym - Double court	13,300		1	13,300
Fitness Studios	2,000		1	2,000
Locker/showers	1,200		2	2,400
Indoor Sports and fitness NSF				17,700
Pool				
Pool				
Short course	7,000	300	1	7,000
Long course	10,824			
Mechanical/storage	1,000		1	1,000
Pool NSF				8,000
Subtotal Program Areas				
Efficiency factor				70%
TOTAL BUILDING GSF				57,900
Outdoor space				
Entry Court / Gathering Space	1,500		1	1,500
Play space (optional, where site allows)	2,000		1	2,000
Rooftop open space				
Garden	1,000			-
Garden classroom			1	-
Parking	288		5	1,440
Outdoor Space NSF				4,940

the engagement process.

Gray text represents an alternate option that was considered but not included in program parameters and do not contribute to SF totals. These items are included for future reference.

Assumptions

The program metrics assume 70% building efficiency that will change based on the final building configuration and site. Maximum occupancy is based on Massachusetts State Building Code 780 CMR and IBC 2015 Table 1004.1.2.4

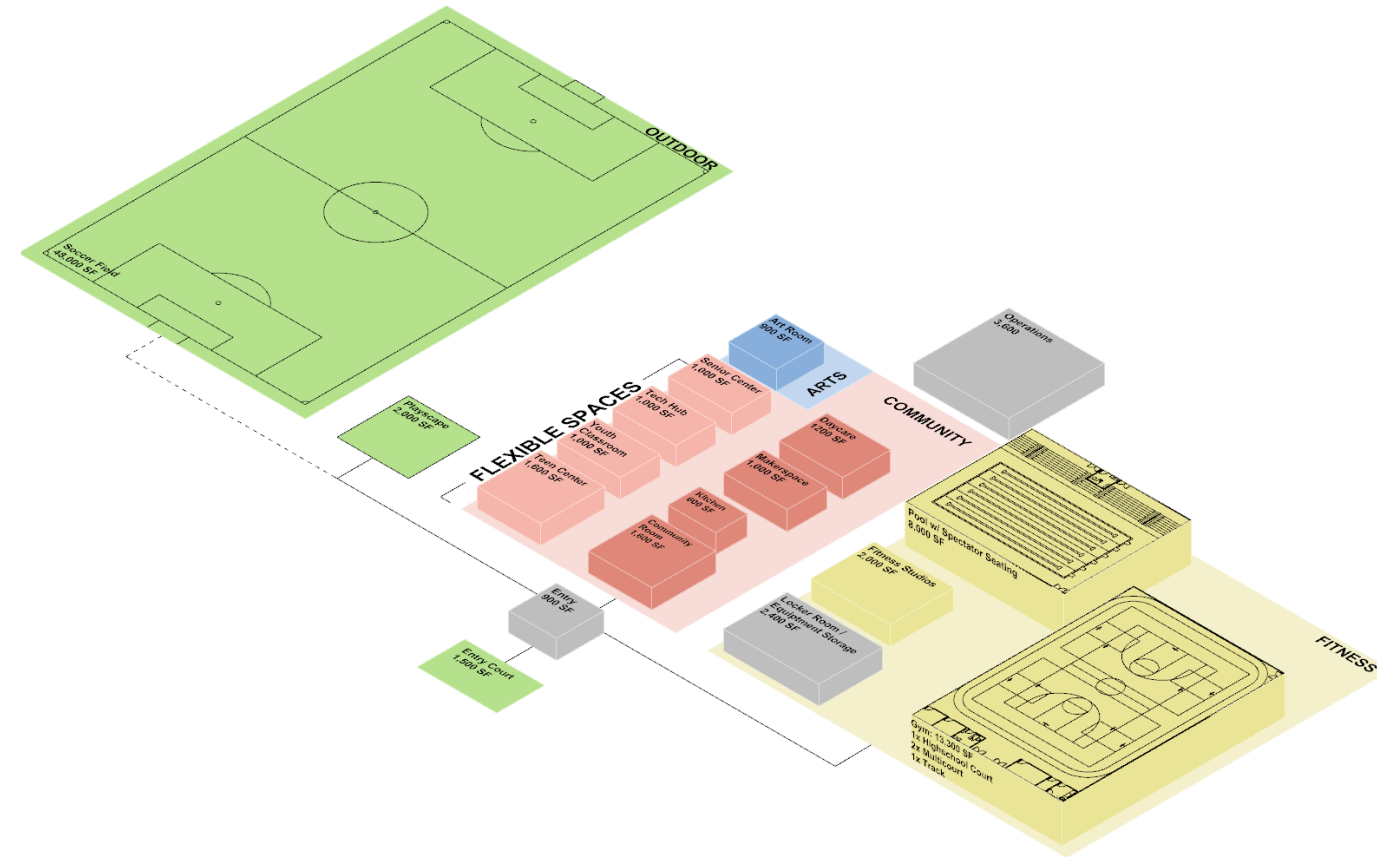

The above diagram illustrates the variety and overall comparative size (footprint and height) of each activity space designated within the program metrics and room sheets that follow. Activity spaces are nested within the category they correlate with.

Program Options

In an effort to provide flexibility in selecting sites in Charlestown, the program was configured into two options:

The "Ideal Program" reflecting all of the uses and activities identified in the study stacked and distributed across multiple floors.

The "Compact/Shared Program" relies on shared pool and gym facilities with the neighboring Charlestown High School, therefore it provides a smaller gym and does not include a swimming pool.

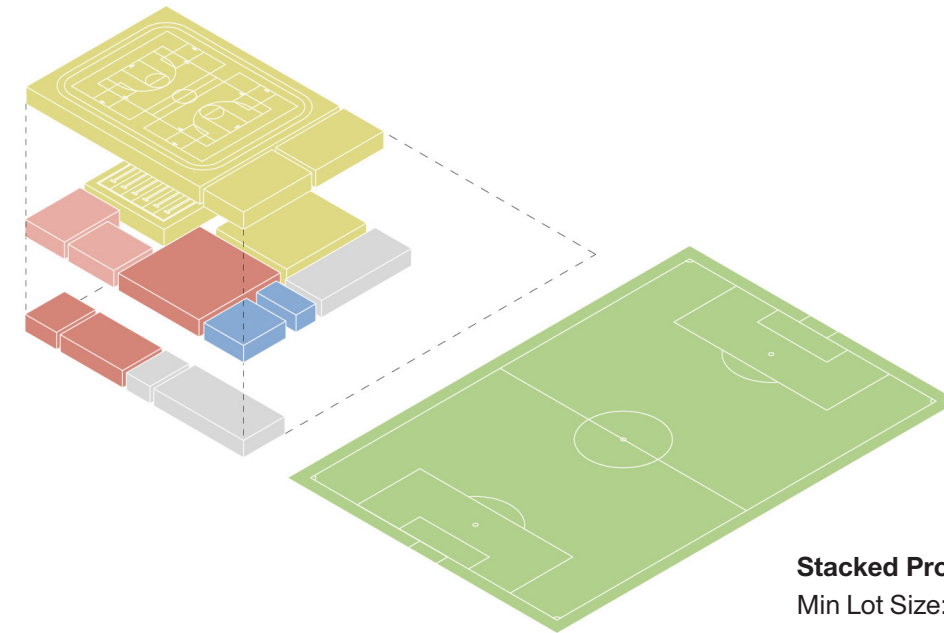

Stacked Program (Multi-Level)
Min Lot Size: 24,000 SF

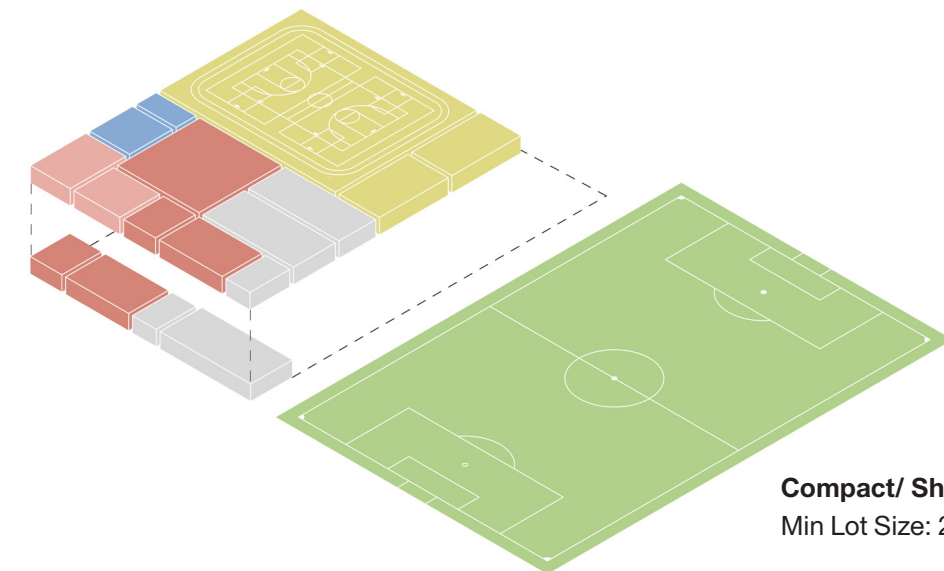

Compact/ Shared Program (No Pool)
Min Lot Size: 24,000 SF

4.2 Room Sheets

Entry Court

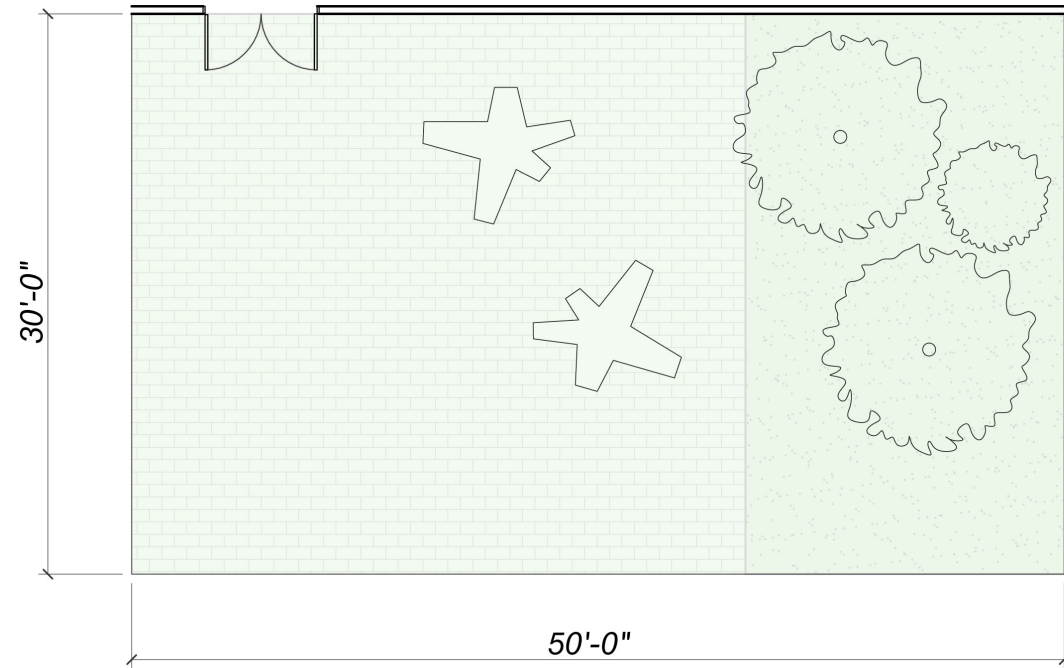

Entry Court

Area	1,500 SF
Occupants	20
Description	Open, accessible, and welcoming space with seating and landscaping leading to the building entrance. Includes benches and space for visitors to informally gather, wait, and socialize.
Adjacencies	Direct connection from the street to the entry lobby. Can have visual connections to interior community programs. Incompatible: None
Fixtures	Fixed: seating, landscaping, lighting, overhead canopy Flexible: seating but with security locks



Entrance to the Roxbury Branch of the Boston Public Library

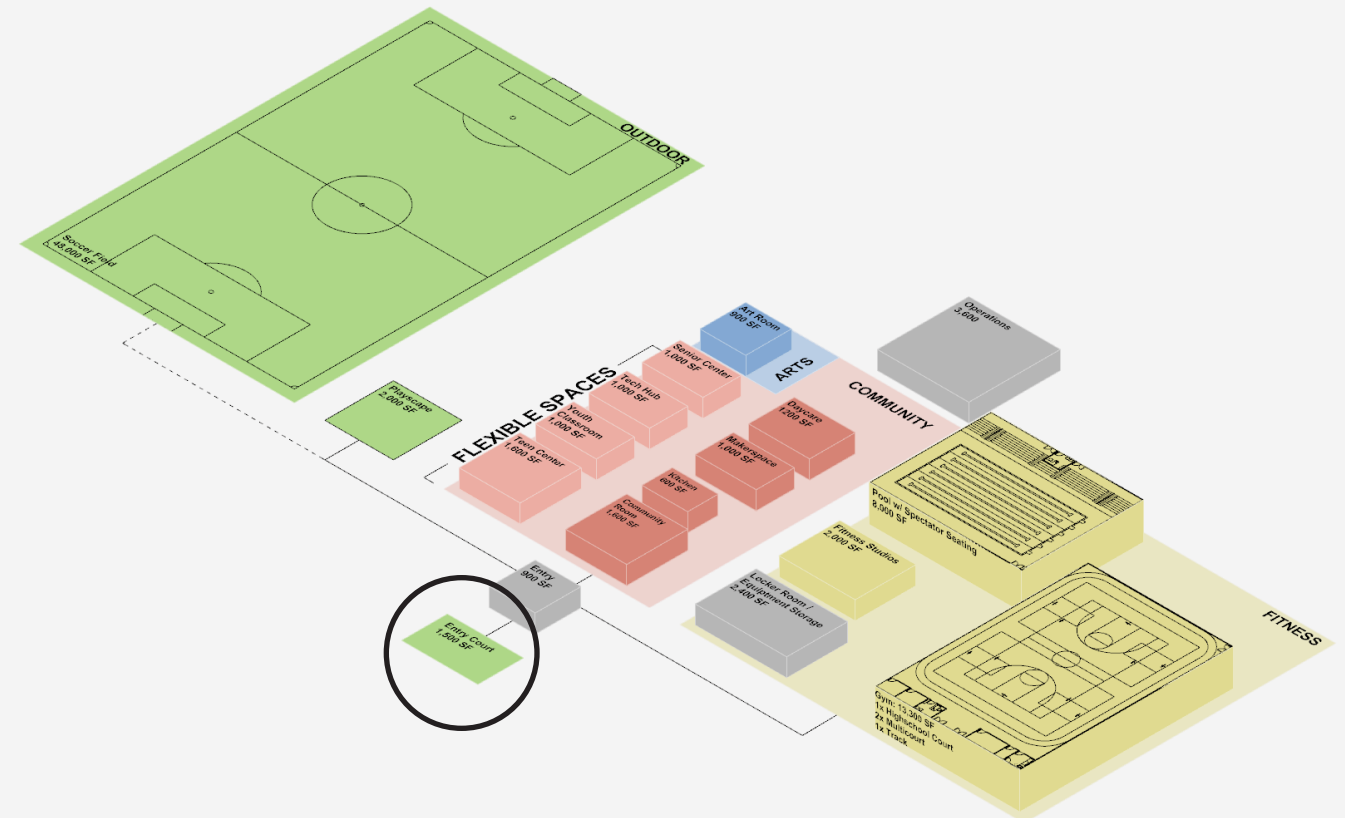

Entry Lobby

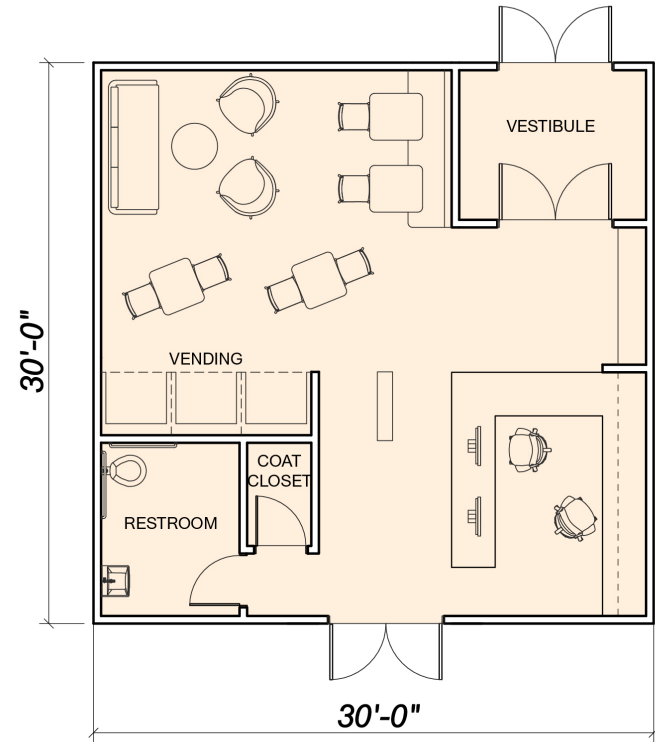

Entry lobby at BCYF Paris St.

Entry Lobby

Area (Net SF)	900 SF
Occupants	Lobby - 20 MAX during events; Reception desk - 2
Description	Open, welcoming space with access and visual connections to the center's interior programs, allowing supervision by reception. Seating and space for temporary visitors to informally gather and socialize. Includes ADA, family friendly restroom within sight line of reception desk.
Adjacencies	Ideal: Direct connection to assembly and community rooms, visual connections to other programs like the gym, and proximity to youth and children's room. Incompatible: None
Fixtures	Fixed: storage, reception desk, bulletin area Flexible: seating, vending machines

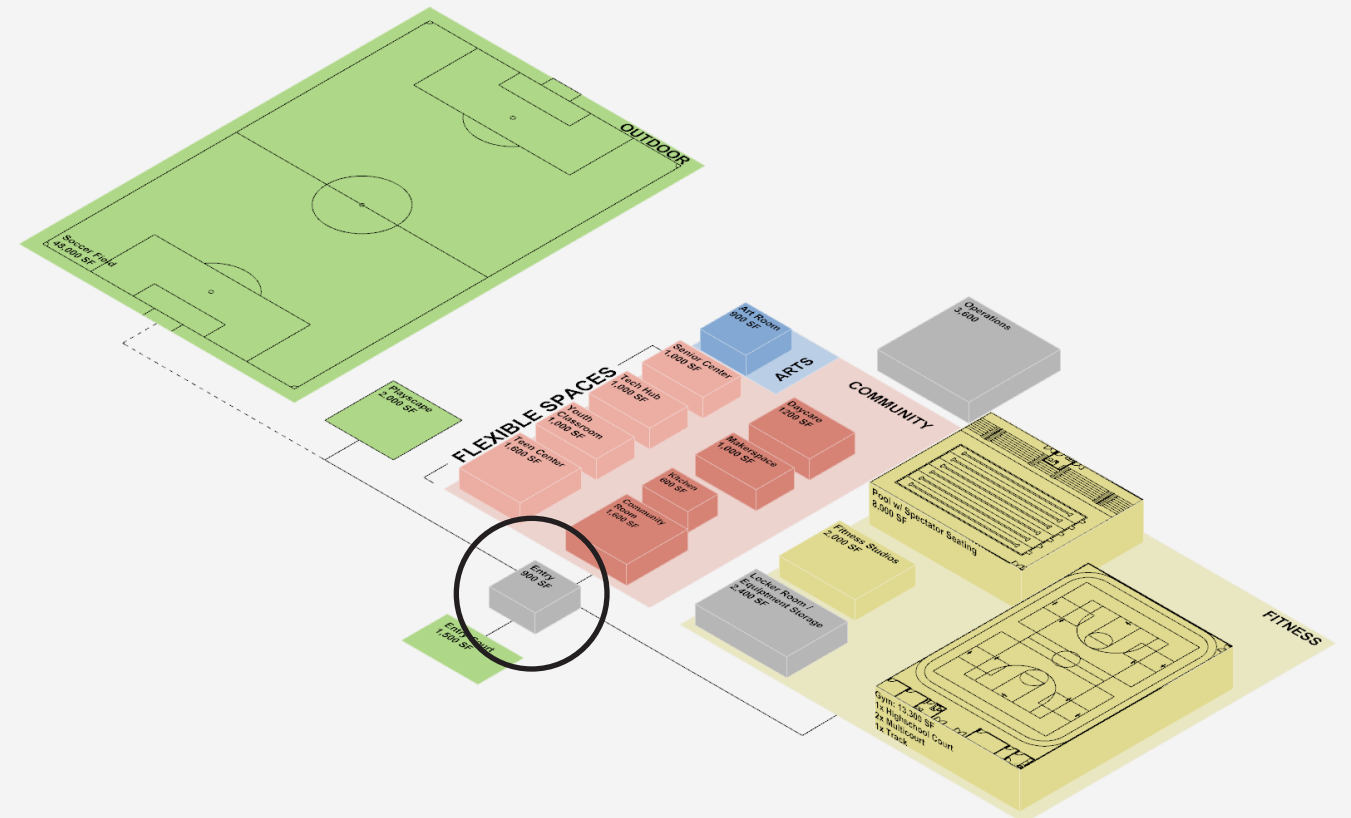

Teen Center

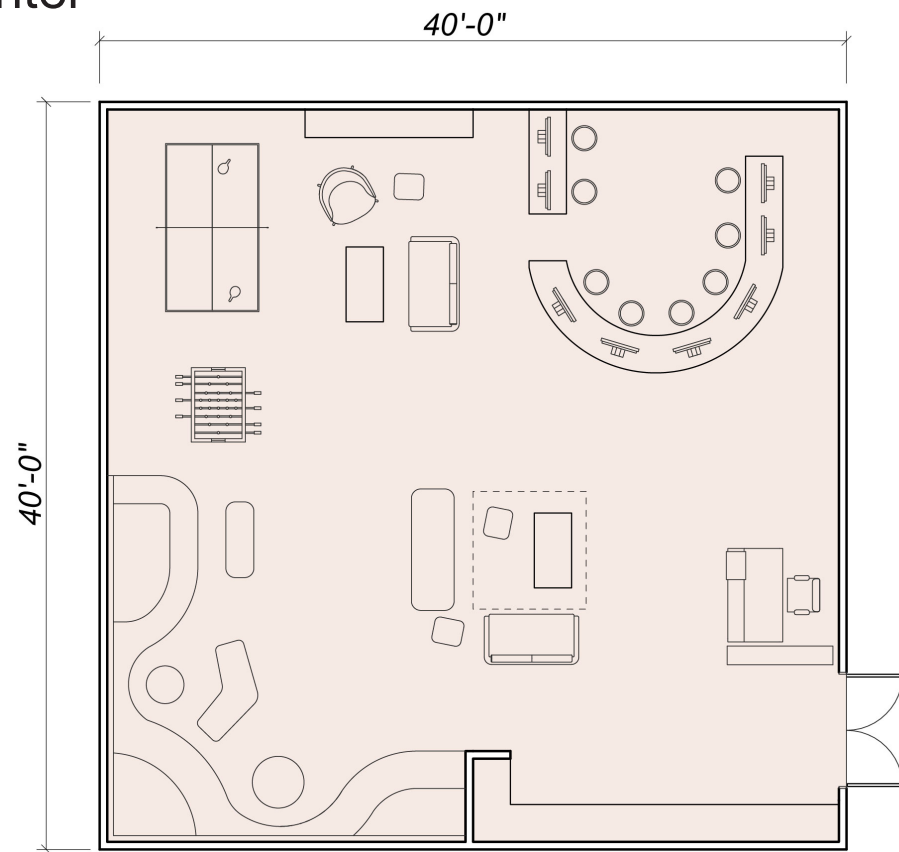

A teen space with a variety of areas for socializing and working.

Teen Center

Area (Net SF)	1,600 SF
Occupants	80 MAX
Description	Flexible space for teens with a variety of areas for socializing, studying, lounging, and after-school activities. Space should feel independent and unique for its teen users.
Adjacencies	Ideal: Near the art room, Tech Lab, Makerspace, and gym. Can be independent from other programs. Incompatible: Youth class room, Youth Flex Room, Senior Center
Fixtures	Fixed: storage (millwork and closets) Flexible: seating, gaming equipment, tables

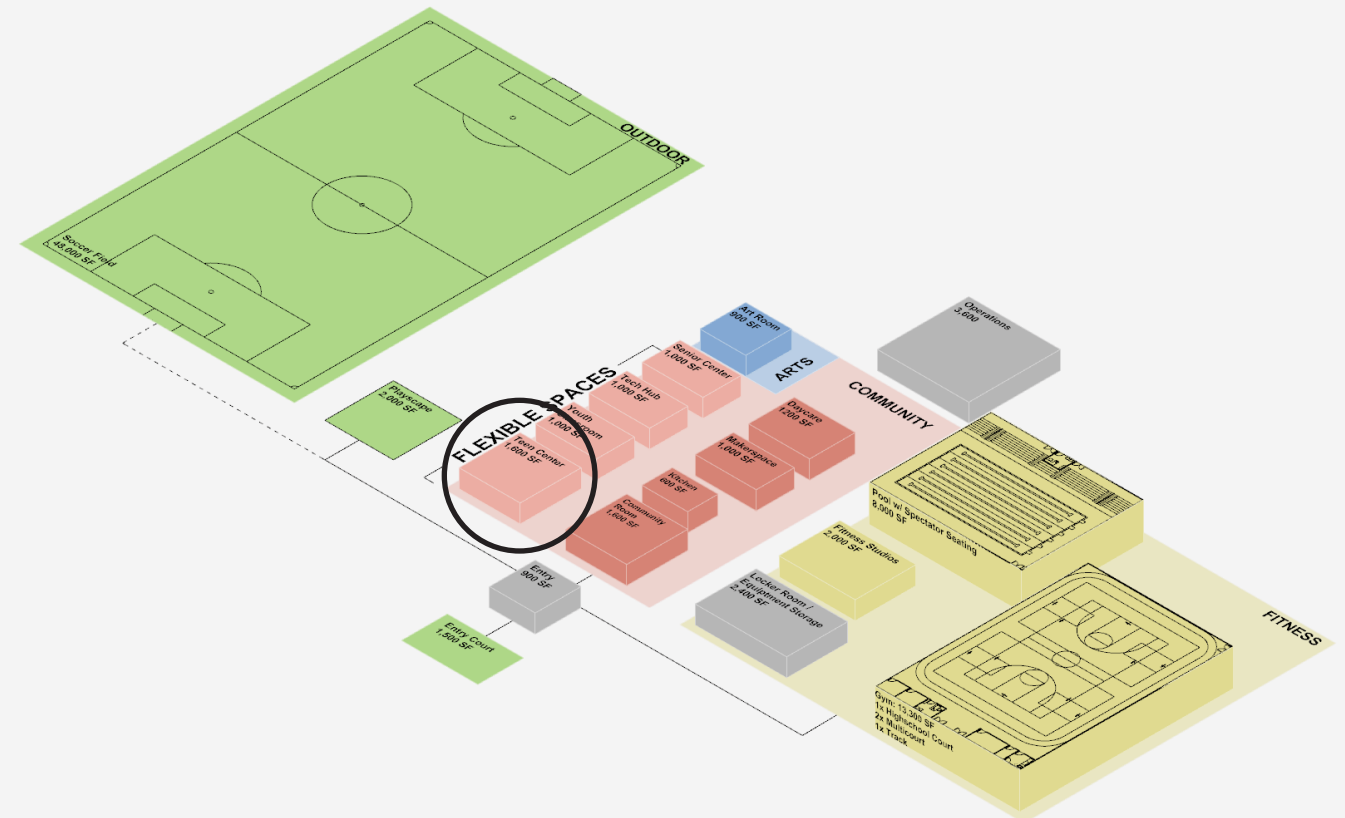

Flex Youth Space

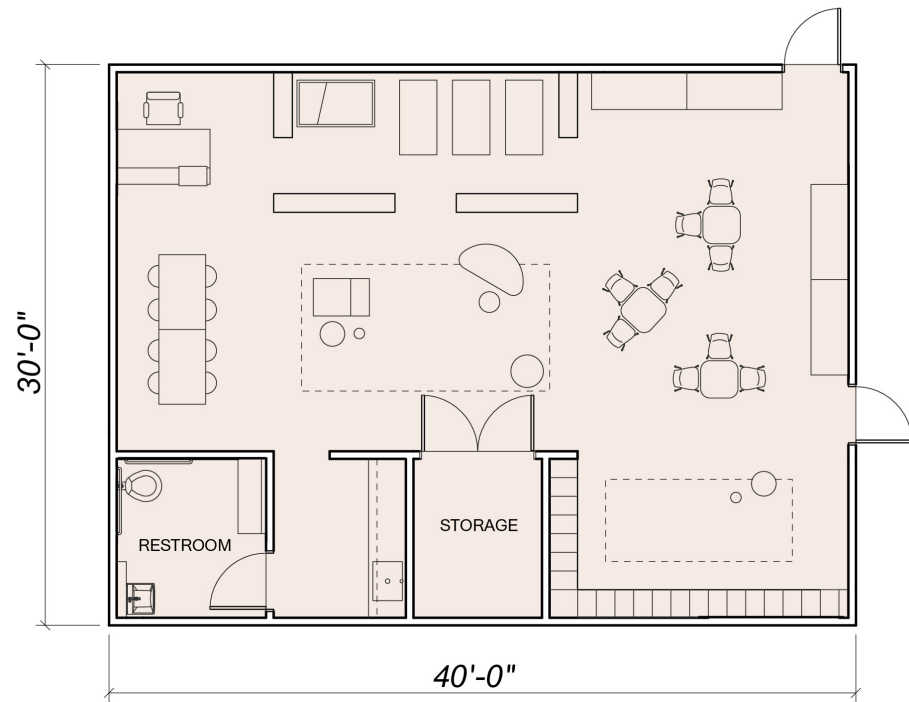

A flexible activity space that can be used as a children's room.

Youth Flex Space

Area (Net SF)	1,200 SF
Occupants	34
Description	Flexible youth space with potential for daycare accreditation, to be used with adult supervision. Has storage for strollers, flexible play area, and children's restrooms.
Adjacencies	Ideal: Outdoor playspaces and entry lobby. Incompatible: Teen Center and Senior Center
Fixtures	Fixed: storage (millwork and/or closets) sink and counter; children's restroom Flexible: tables and chairs, play equipment

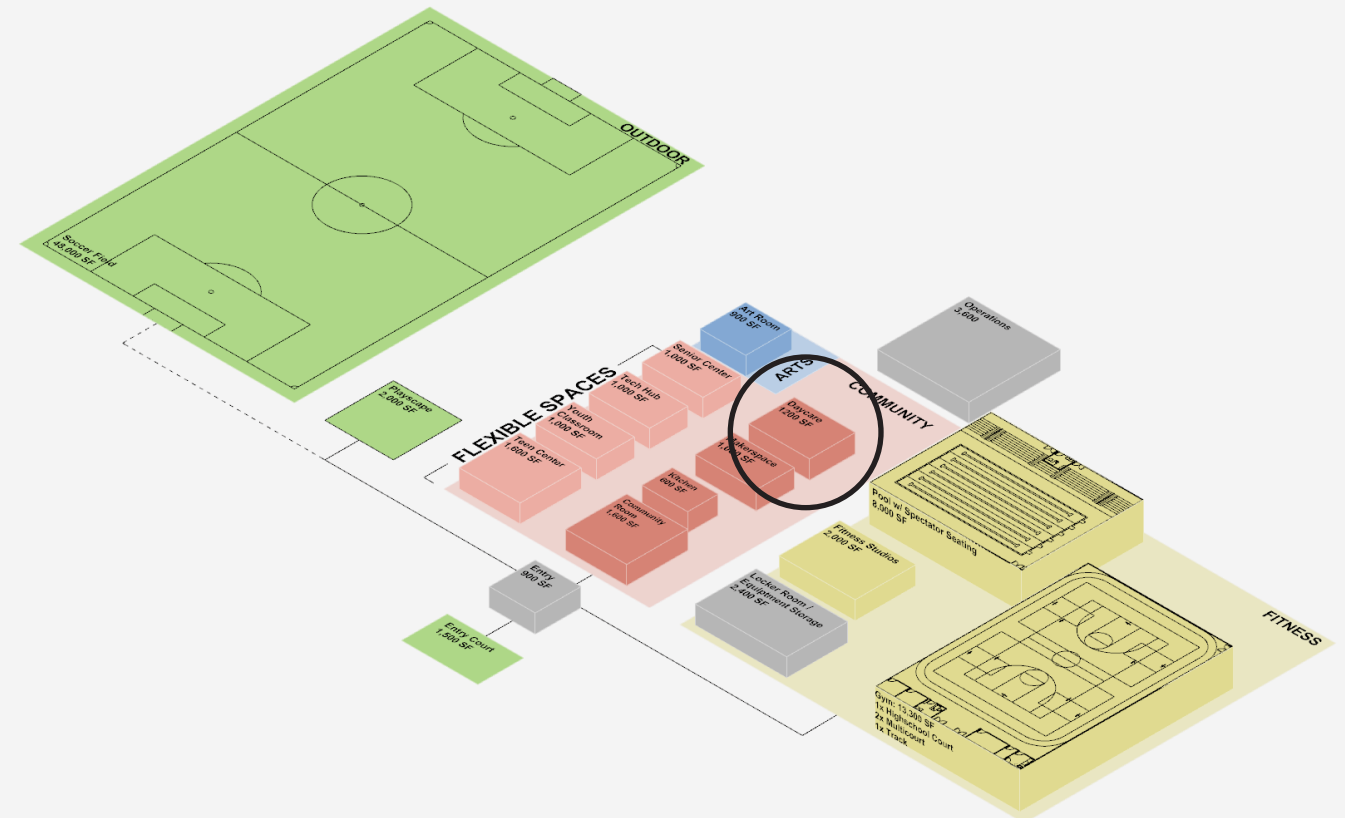

Tech Lab and Makerspace

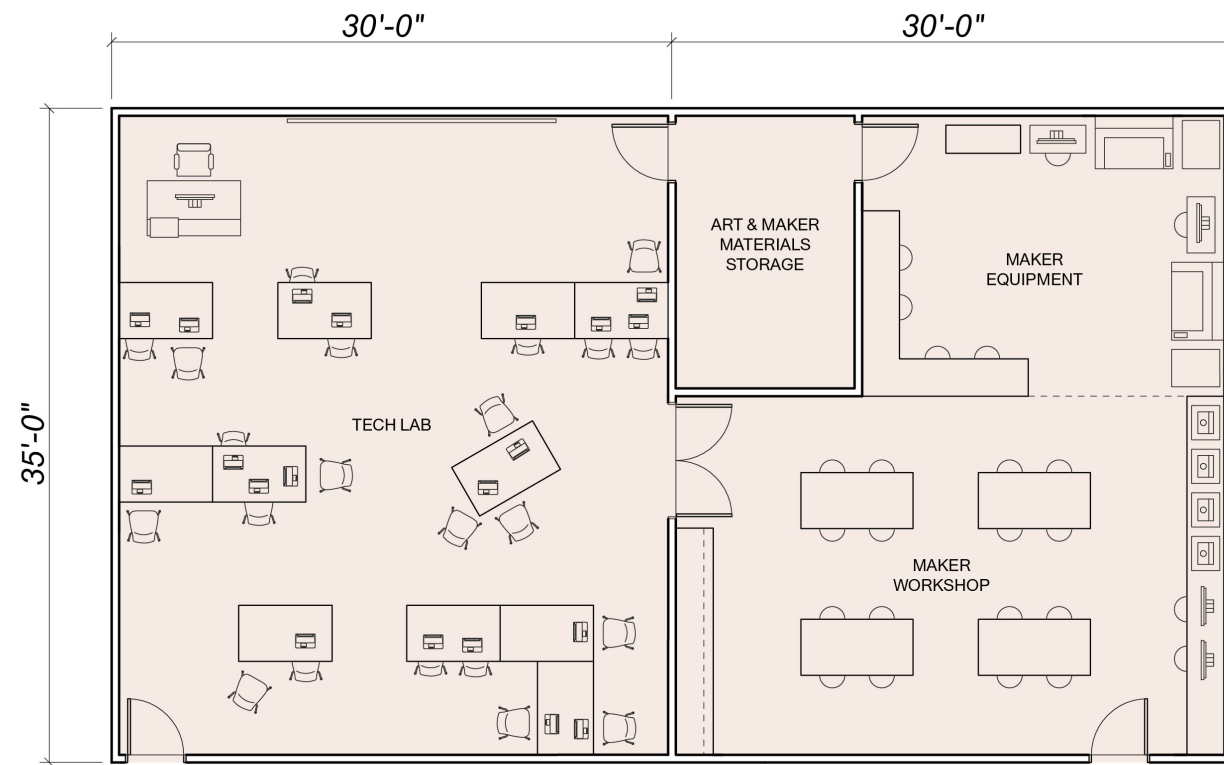

Tech Lab and Makerspace

Area (Net SF)	2,100 SF
Occupants	Tech Lab: 30 Makerspace: 30
Description	Dedicated Tech Lab for individual use, educational programs, and testing. Connects to makerspace with focus on digital and physical fabrication.
Adjacencies	Ideal: Art room, Teen center Incompatible: Gym, children's room, pool
Fixtures	Fixed: storage (millwork and closet) Flexible: tables and chairs, laser cutters, 3D printers, sewing machines, peg boards and tools, computers, laptop cart



A computer lab with a lecture layout.



Belmont Hill School Bolles Makerspace

Senior Center

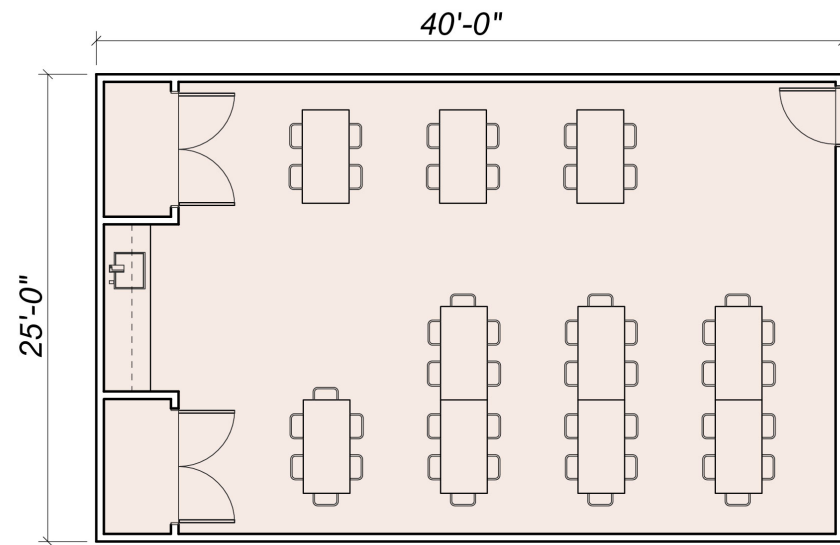

A senior room with flexible, lightweight furniture for a variety of activities.

Senior Center

Area (Net SF) 1,000 SF

Occupants 50

Description Flexible space for senior programming, lounging and socializing. Depending on use and programming, schedule can overlap with other programs such as parts of the community room. Includes storage space for activity equipment, tables, and chairs.

Adjacencies Ideal: kitchen, ADA restroom
Incompatible: Gym, children's room, youth room, and teen center

Fixtures Fixed: storage (millwork and closets), sink
Flexible: tables and chairs

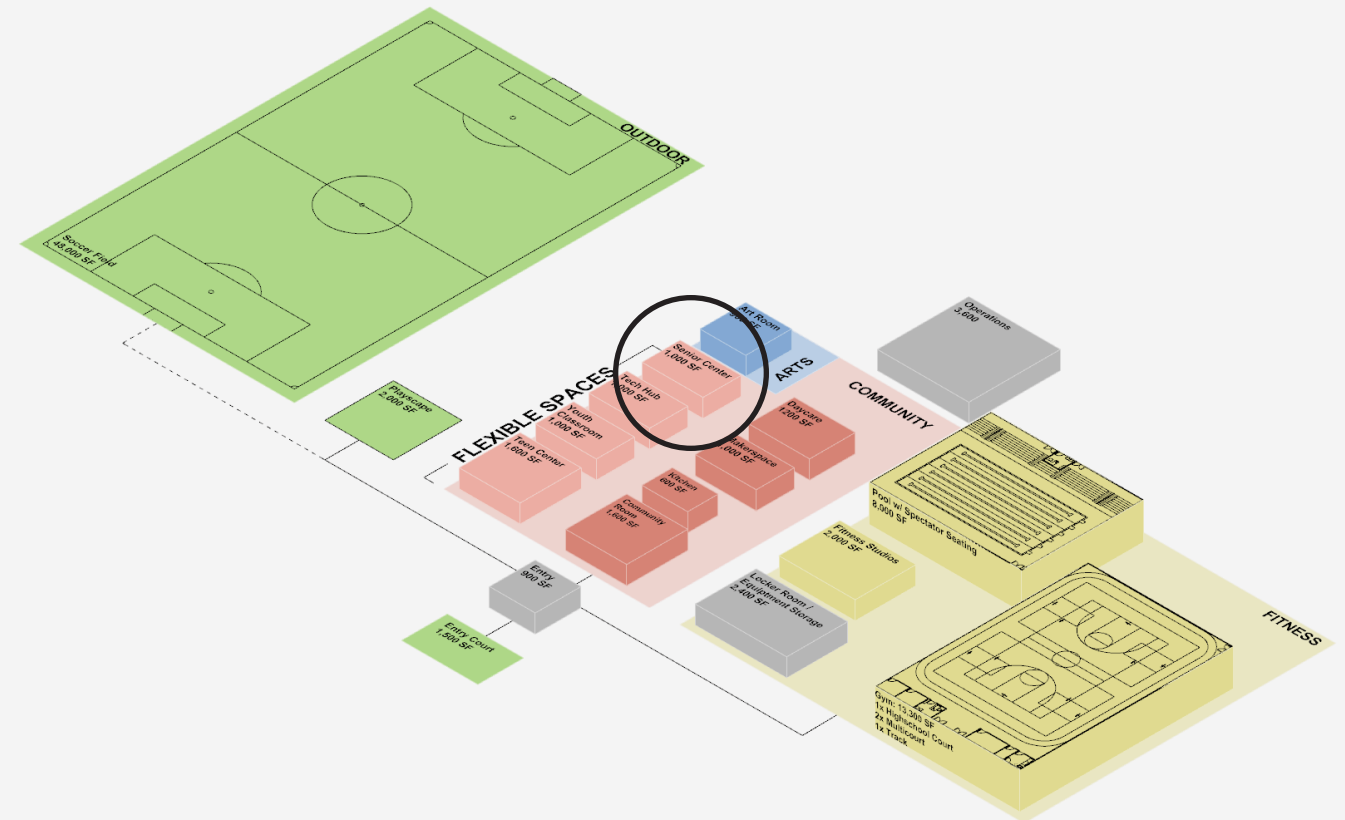

Community Room

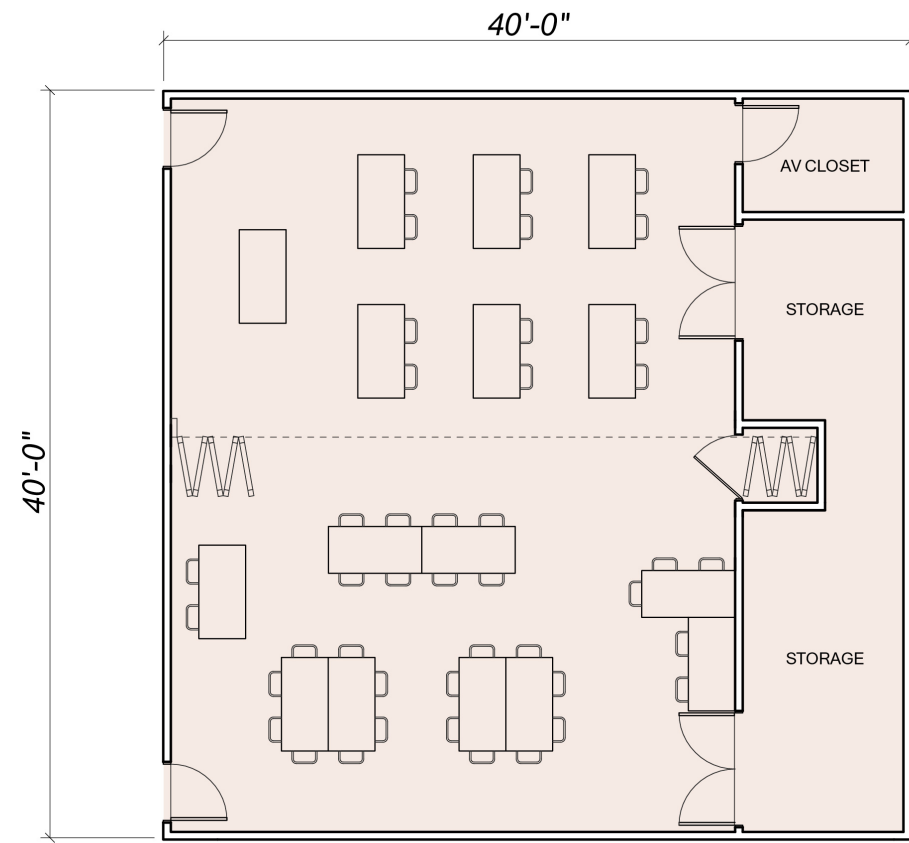

The community room can be partitioned into smaller breakout rooms using flexible partitions.

Community Room

Area (Net SF)	1,600 SF
Occupants	80
Description	Flexible meeting space that can be rearranged and divided for group meetings and events. Can be combined with the kitchen space. Includes storage closet for tables and chairs, and an AV closet, as well as special lighting, acoustics, and audio/video equipment for performance
Adjacencies	Ideal: Kitchen, direct access to entry lobby Incompatible: Gym, fitness studio, pool, makerspace, and other noise-generating programs
Fixtures	Fixed: storage (closets), folding acoustic partition Flexible: tables and chairs,

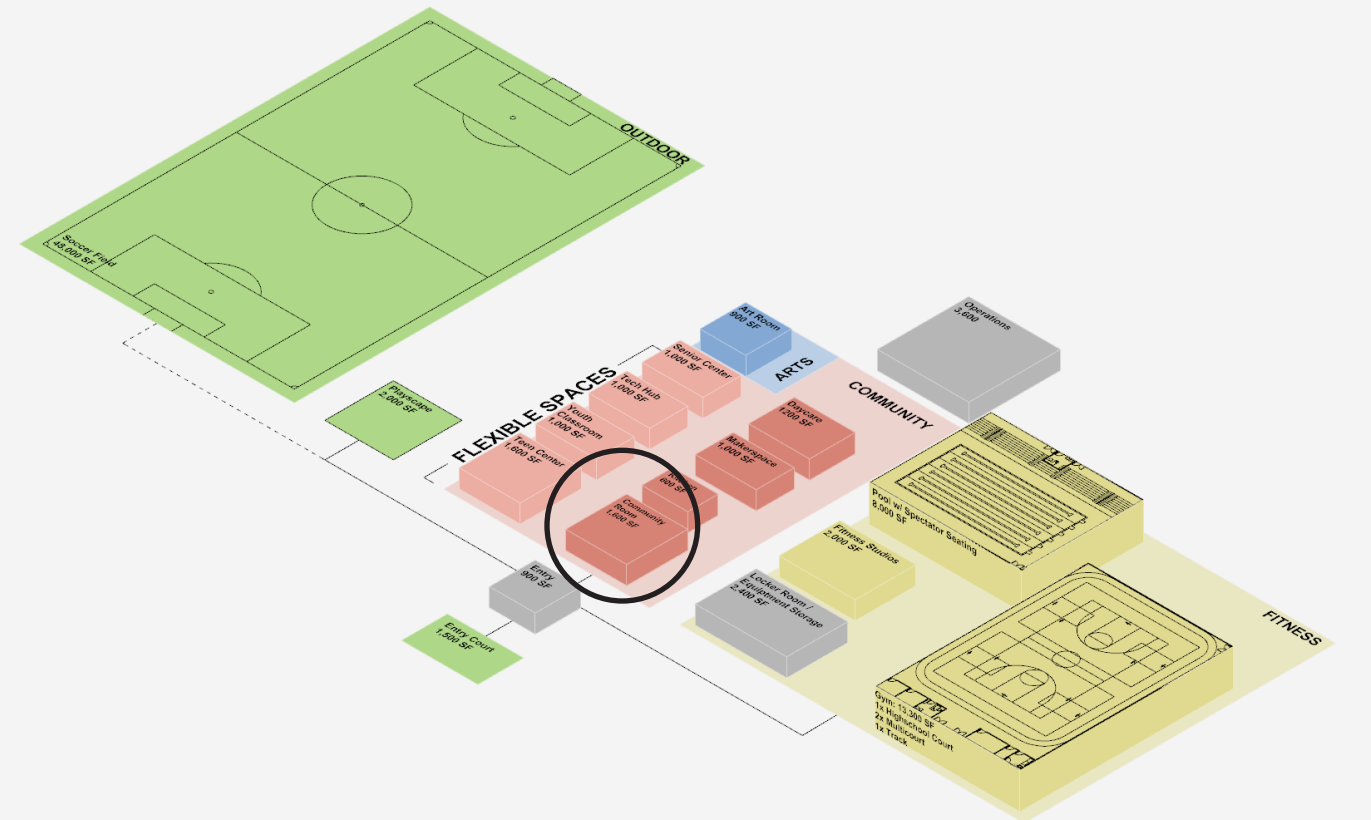

Community Kitchen

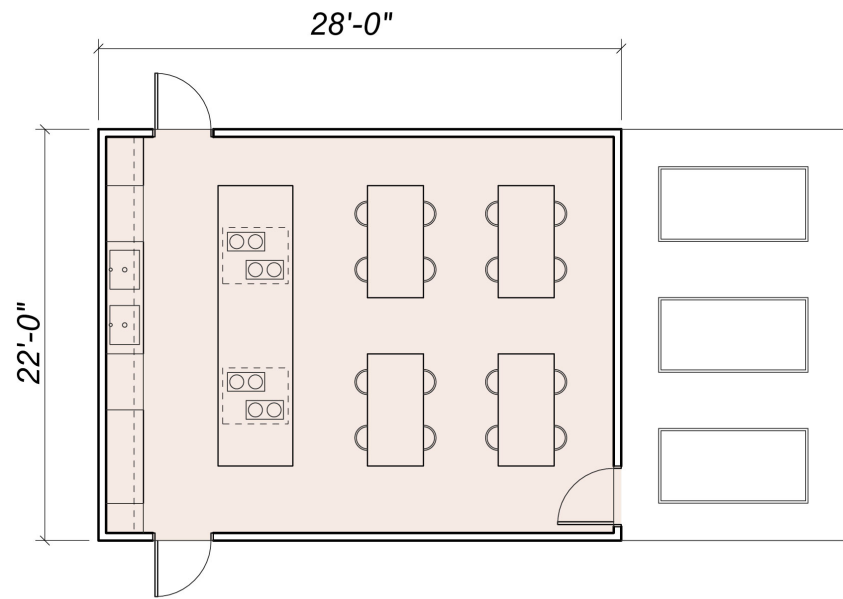

A kitchen can serve the center as a small food preparation area as well as a teaching space.

Community Kitchen

Area (Net SF)	600 SF
Occupants	20
Description	Small scale kitchen for minor food preparation. Can be combined with the community room and used as a nutrition lab. Access to outdoor area for growing fresh produce. Special consideration for intended food production and consumption to coordinate with public health regulations
Adjacencies	Ideal: combined with community room, nearby senior center, access to outdoor area with garden beds Incompatible: Locker rooms and pool to control odor and intrusion
Fixtures	Fixed: storage (millwork), stove, cook top, sink, dishwasher, island, Kitchen exhaust hood with integral fire suppression system Flexible: counter-height stools and tables with casters

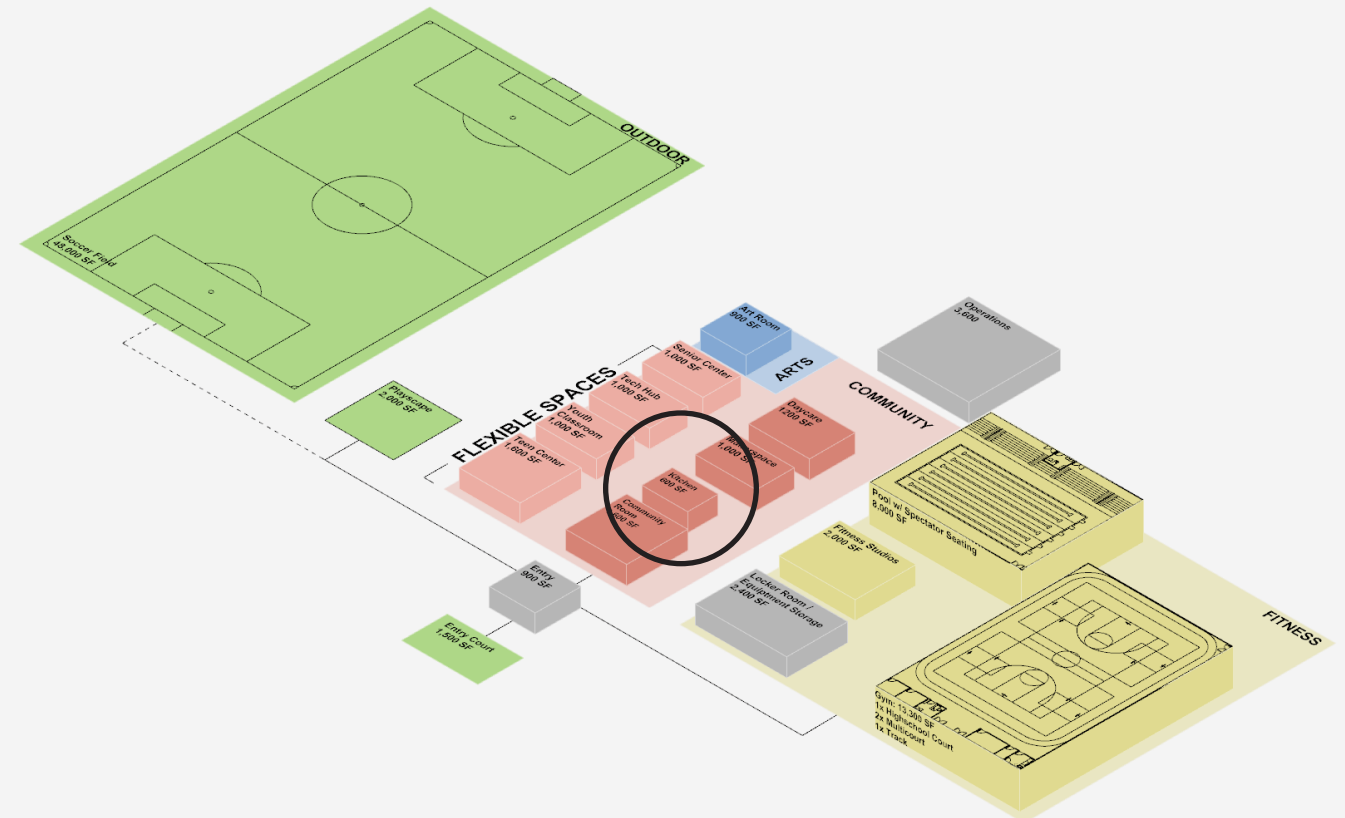

Art Room

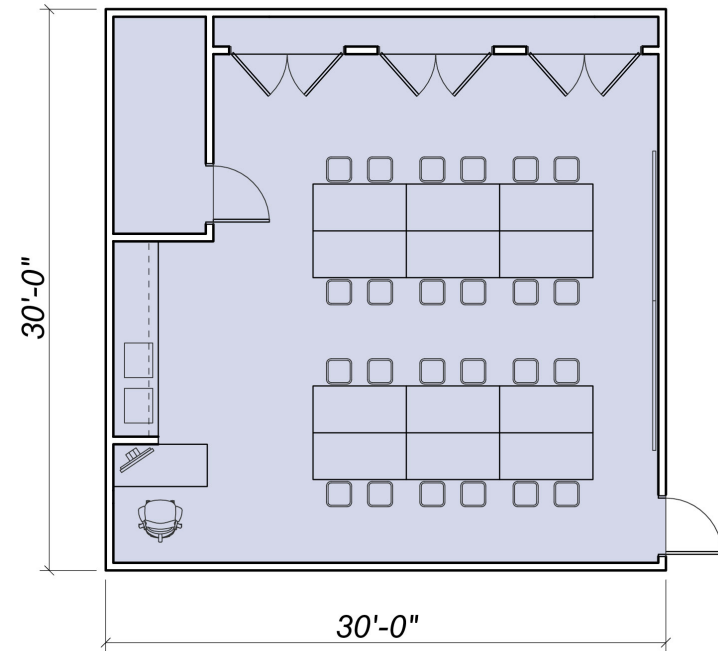

Art Room

Area (Net SF)	900 SF
Occupants	25
Description	Flexible art room for crafts, drawing, painting, etc. Potentially has additional spaces for fixed art equipment such as pottery or woodworking equipment.
Adjacencies	Ideal: direct connection to entry lobby for all day access, proximity to community room, youth room, teen center, senior center Incompatible: -
Fixtures	Fixed: storage (millwork and closets), sinks Flexible: tables and chairs



An art room with several different storage areas and flexible work surfaces.

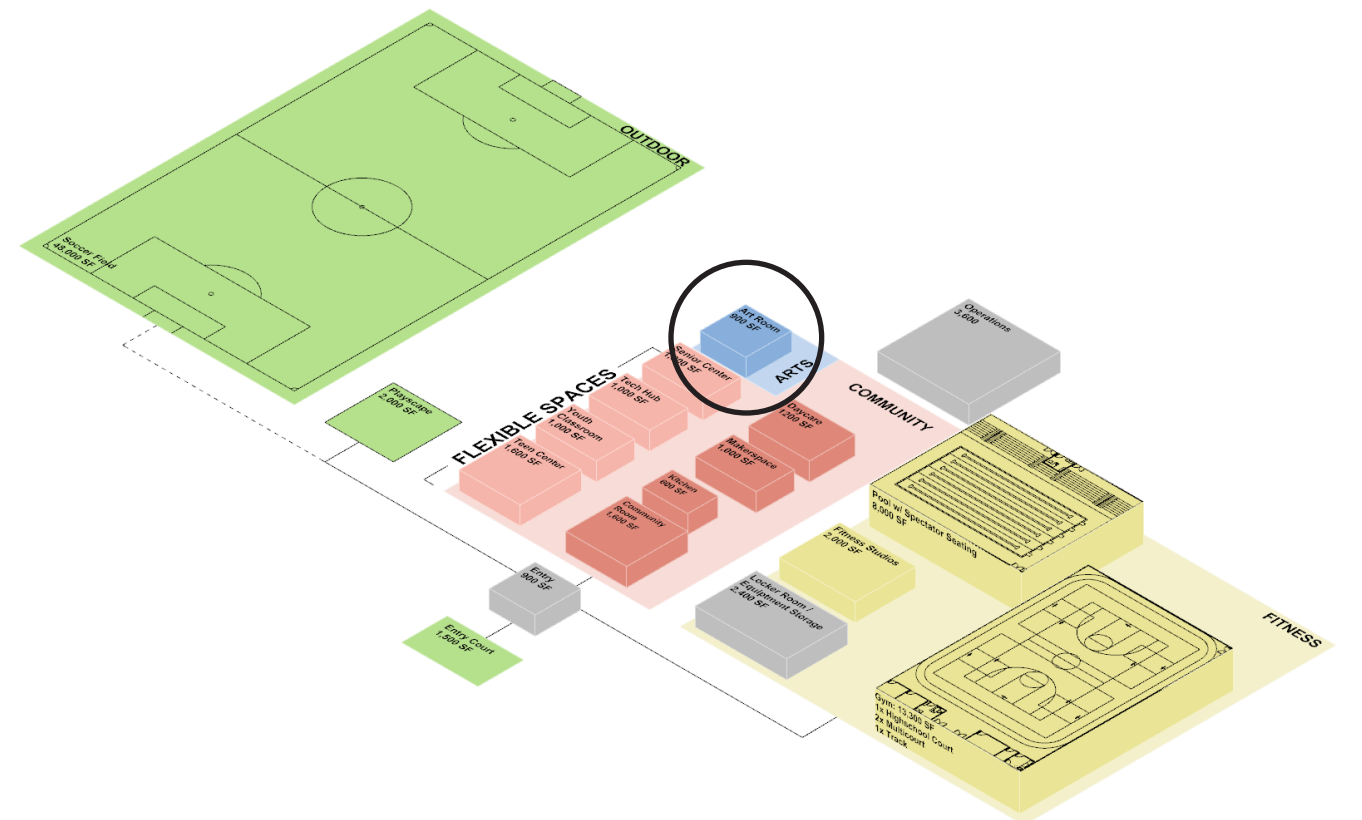

Gymnasium

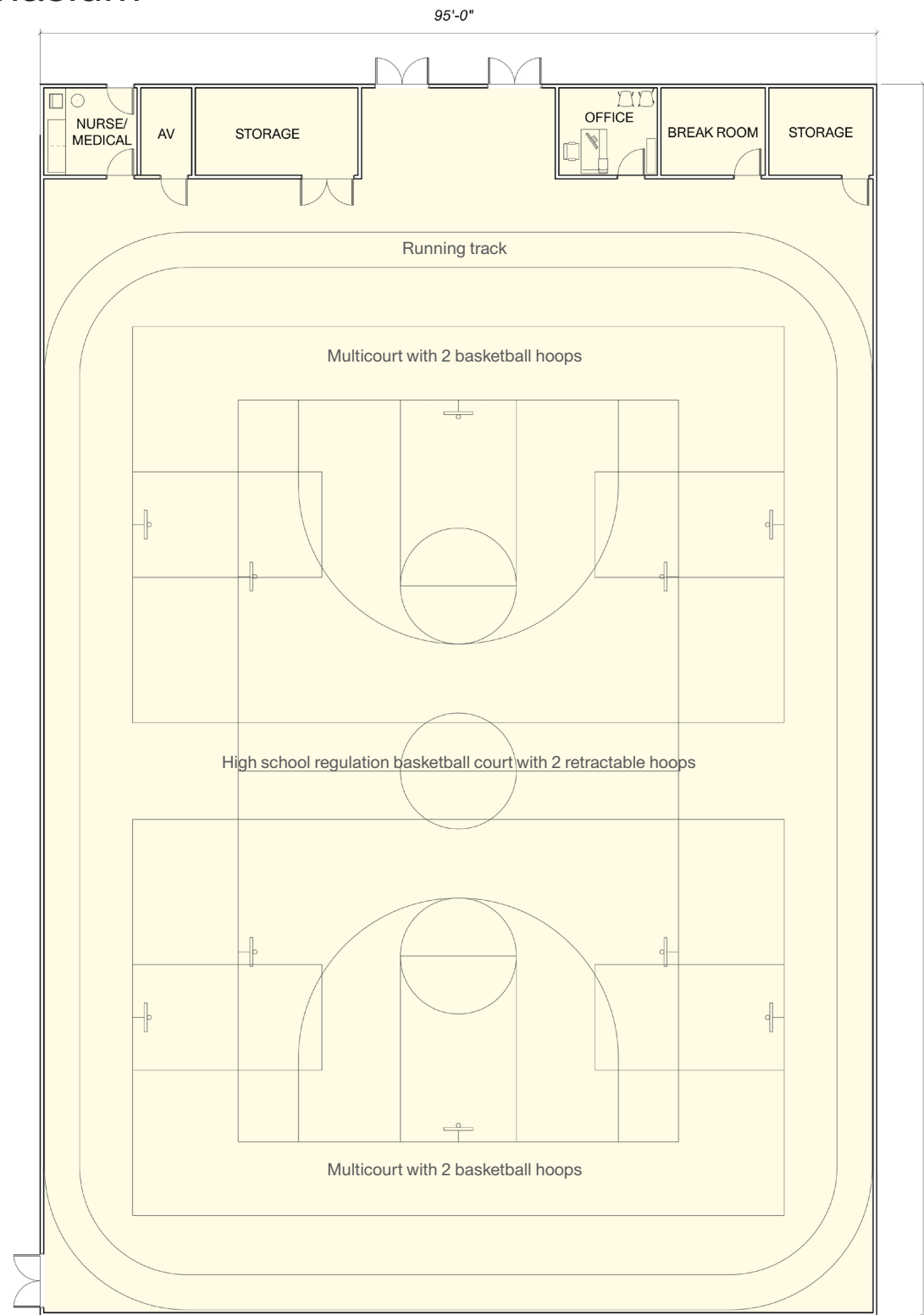

Gymnasium

Area (Net SF) 13,300 SF

Occupants 250

Description 1 high school regulation court that can be divided into 2 multi courts with basketball hoops and an area that can accommodate a batting cage.

Heavily used by the community and, depending on the location, local schools. Ideally large enough to accommodate different sports that can be divided by partitions and run simultaneously including a batting cage, basketball courts, and flexible multi-courts. A running track is located at the perimeter of the court to avoid conflicting activities. Includes equipment storage closets, staff office, break room for private one-on-one meetings / cooling off space, nurse/medical office and AV equipment storage

Adjacencies Ideal: Locker rooms, fitness studios, entry lobby, outdoor space, and visual connection to other programs
Incompatible: youth classroom, daycare, senior center, community room

Fixtures Fixed: 6 basketball hoops, room dividers, storage, closet; consider retractable bleachers depending on site selection.
Flexible: batting cage, volleyball multicourt equipment



Tobin gym has 1 large basketball court with retractable hoops and 2 smaller scale courts that can be divided by a curtain partition. The gym has retractable seating and space for a batting cage with netting that drops from the ceiling.

Fitness Studios

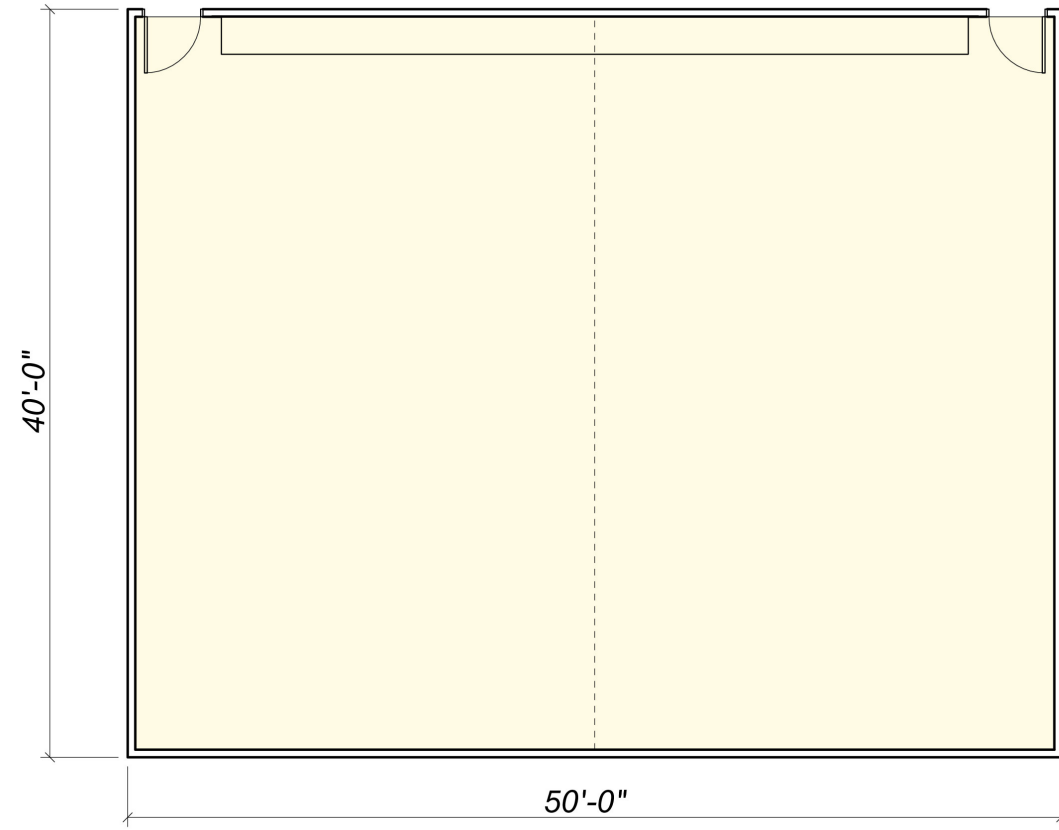

A flexible workout studio that can be used for fitness, classes, dance or yoga.

Fitness Studios

Area (Net SF)	2,000 SF
Occupants	42 people
Description	Flexible workout studio for yoga, mat workouts, dance, and cardio classes. Can become 2 small studios with a flexible partition. Consider sub-dividing studio and outfitting one side with exercise equipment (such as cardio or weights) depending on site selection
Adjacencies	Ideal: Gym and lockers Incompatible: None
Fixtures	Fixed: storage (millwork), mirrors Flexible: exercise equipment, mats

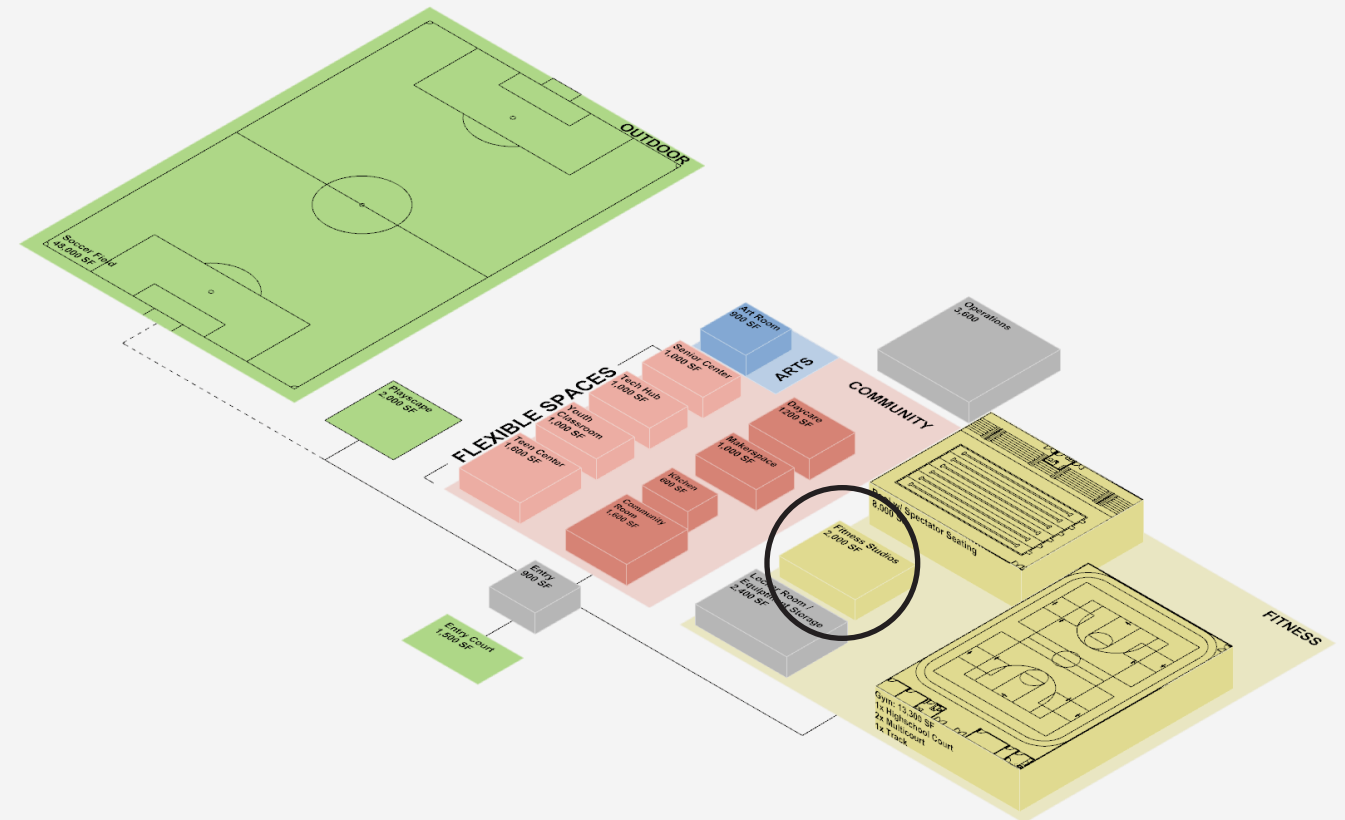

Indoor Pool - Lower Floor

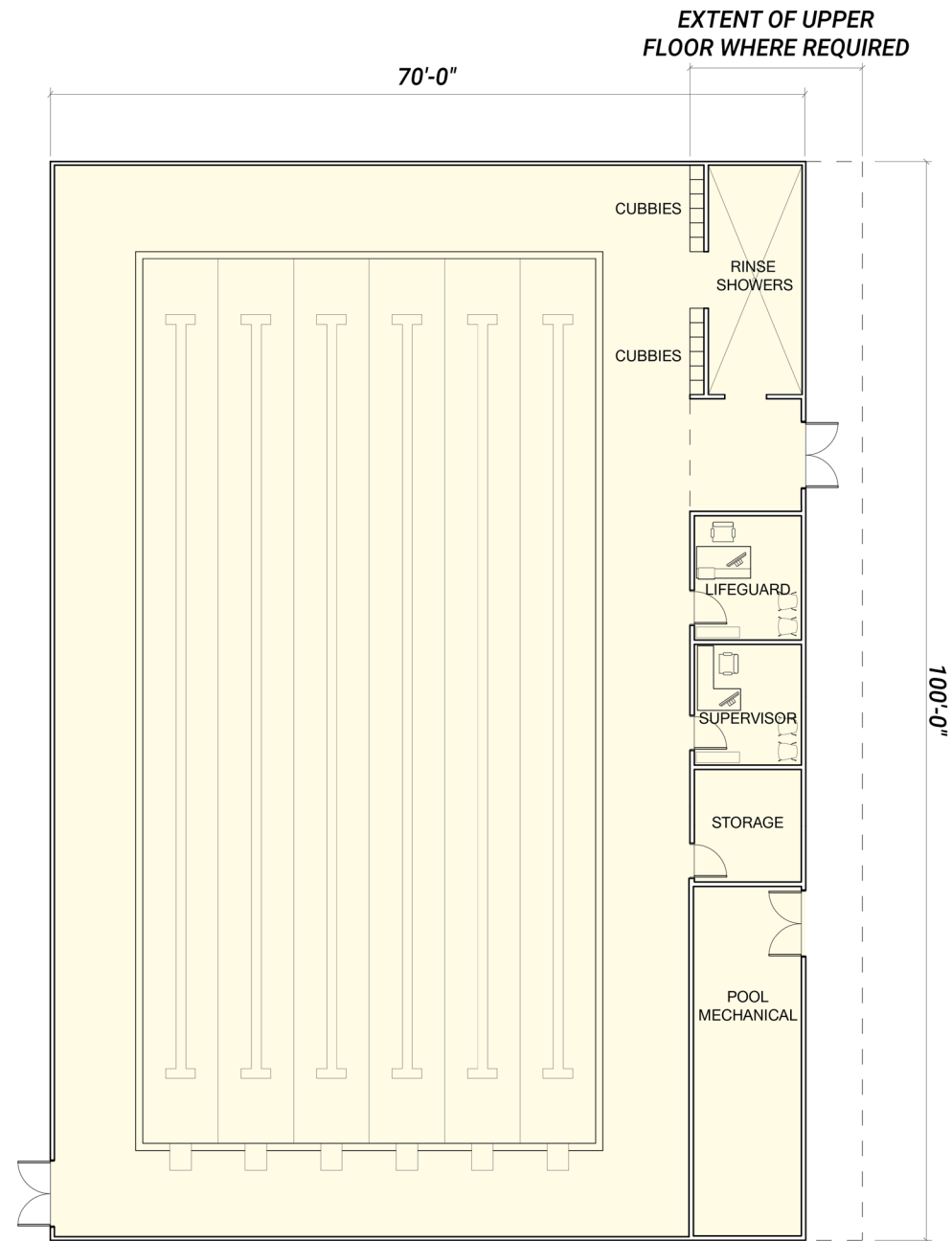

Indoor Pool - Lower Floor

Area (Net SF)	8,000 SF
Occupants	Pool - 80 MAX
Description	6 lane short-course competitive pool. Cubbies and open rinse showers on pool deck. Includes lifeguard and supervisor offices, storage, and pool mechanical space.
Adjacencies	Ideal: Locker room Incompatible: Community Kitchen

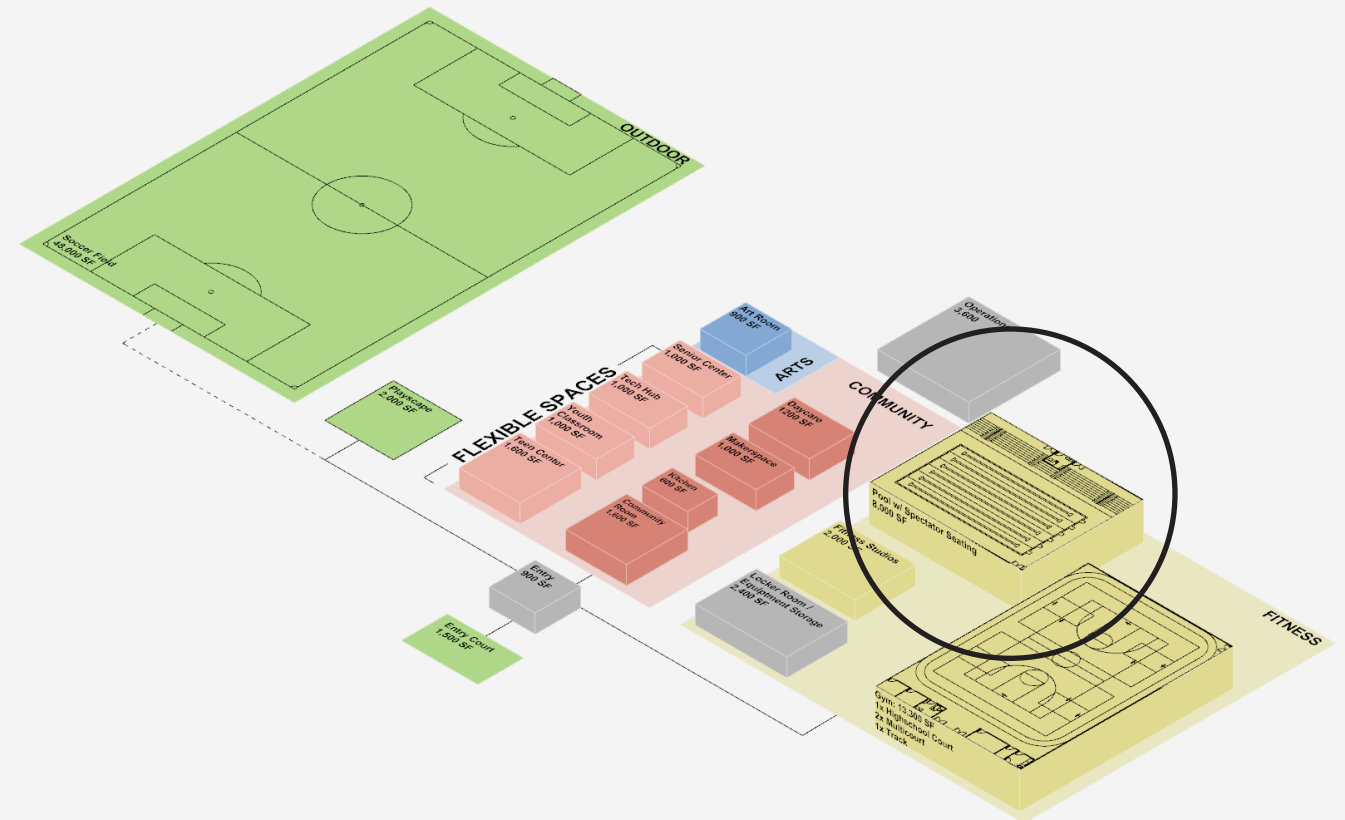

Indoor Pool Upper Floor w/ Spectator Seating

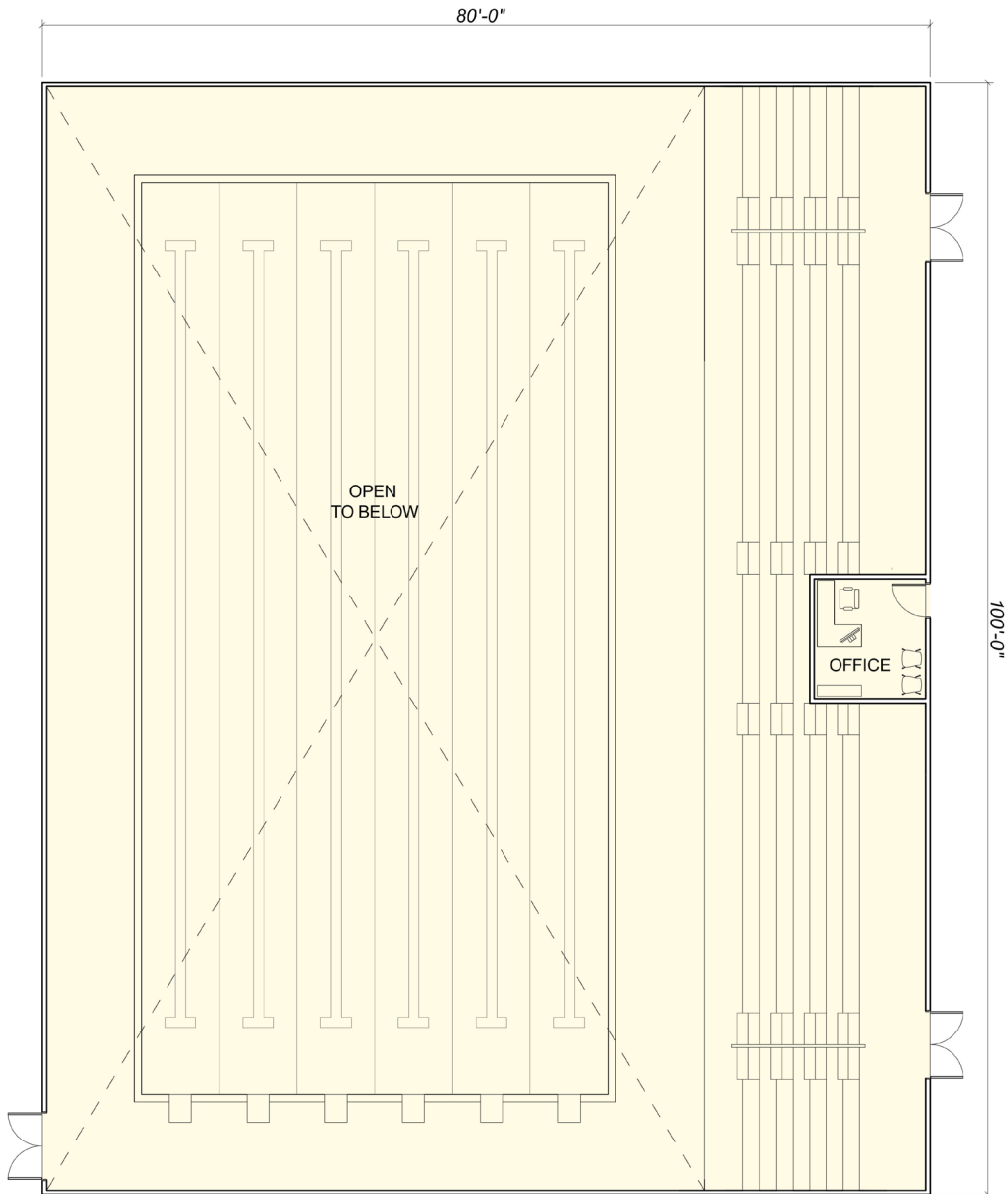

Indoor Pool - Upper Floor with Spectator Seating

Area (Net SF)	2,000 SF
Occupants	Spectator Seating: 200 MAX
Description	Tiered bleacher spectator seating on upper floor of pool area
Adjacencies	Ideal: Lockers and restrooms Incompatible: Community Kitchen

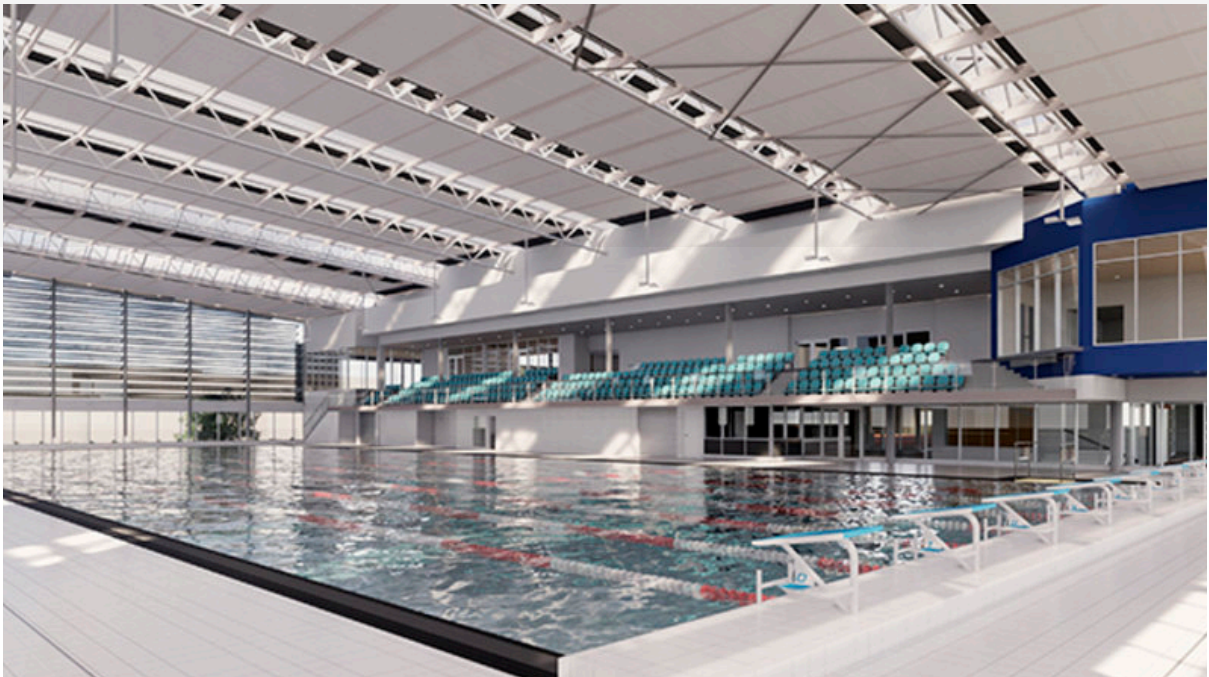

Outdoor Play Space

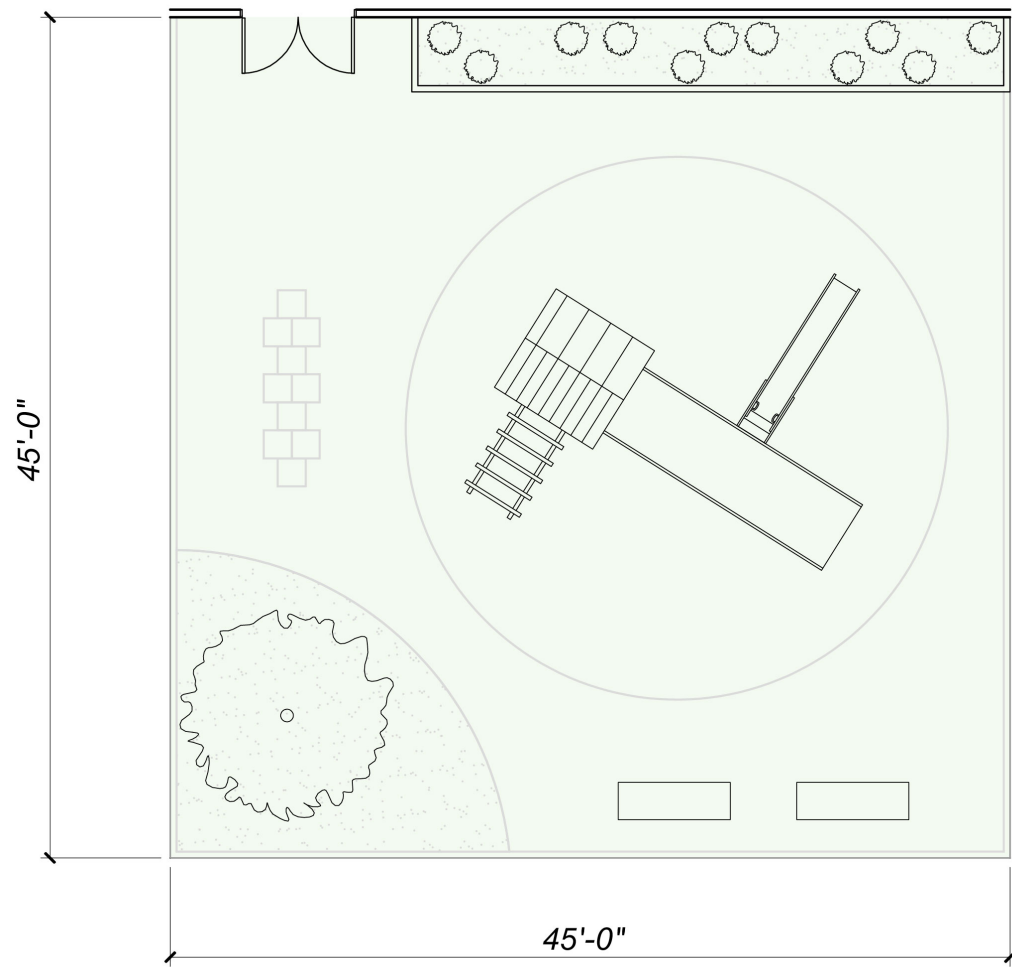

Playground at the Hernandez K-8 School

Outdoor Play Space

Area (Net SF)	2,000 SF
Description	Outdoor space with playground structures and/or park landscaping for flexible play.
Adjacencies	Ideal: Direct connection to youth room, children's room, art room, or community room. Incompatible: -
Fixtures	Fixed: playground structures, seating, landscaping Flexible: play equipment, seating

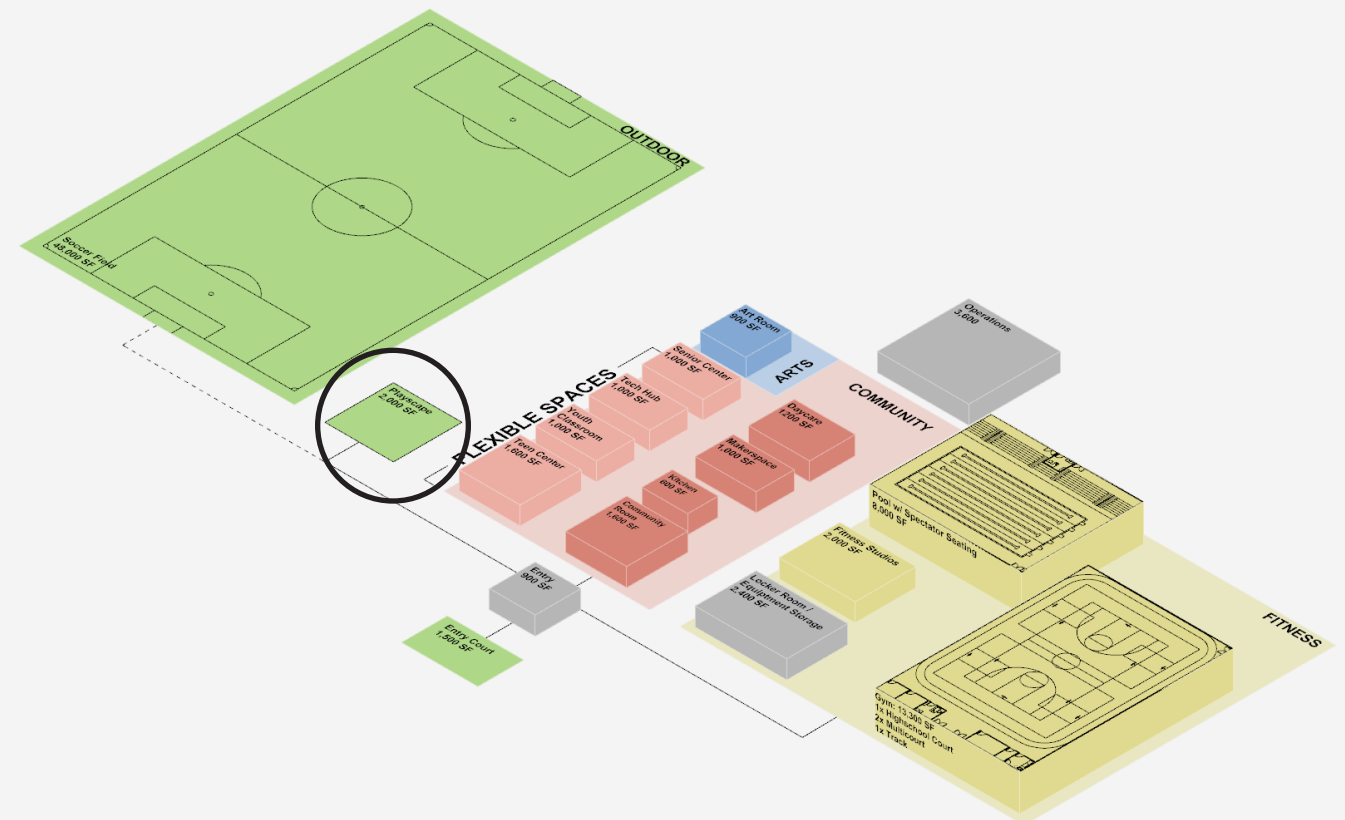

4.3 Net Zero Carbon Goals

A Zero Net Carbon (ZNC) Building is a highly energy efficient building that produces on-site, or procures off-site, enough carbon-free renewable energy to meet building operation energy consumption annually. Meeting the goals of a ZNC building comes with a series of beneficial qualities.

By optimizing the shape and position of the building, ZNC buildings benefit from good quality daylighting and views. Coordination of natural light and electric lighting systems with advanced controls can not only save energy, but promote excellent visual comfort.

Optimization of the building shape and position also bolsters thermal comfort in ZNC spaces. Similarly to balancing natural light and electrical systems. Thermal comfort with minimal overheating or drafts comes with a coordination between the way the structure catches sunlight, and efficient, all electric HVAC systems with excellent temperature control.

Healthy indoor air quality is characteristic of ZNC buildings built with healthy, sustainable materials and mechanical ventilation systems.

These passive strategies to heat and cool the structure and promote comfort save on energy throughout the building's lifespan. The New Buildings Institute (NBI) specified an Energy Use Intensity (EUI) target setting to quantify a target annual energy expenditure for a ZNC building. A pathway towards EUI reduction comes with careful design of the envelope, HVAC, Lighting, other electrical equipment, on-site PV, and off-site renewables.

Goals

The pathway towards ZNC categories includes several main goals:

- **Reduce Loads:** through orientation and massing of the structure to allow for north and south facing, high performance glazing exposures for quality daylight and solar/glare control with exterior solar shading. Continuous exterior insulation with minimal thermal bridges and infiltration maintain consistent interior environments without the need for excess energy use. Overall reduction in lighting loads and use of low-flow fixtures can also reduce energy use.
- **Efficient Equipment:** in heating and cooling systems eliminate of on-site combustion of fossil fuels with all electric properly sized equipment with a high Coefficient of Performance. Efficient Ventilation might come in the form of energy recovery ventilation systems separate from heating and cooling.
- **Renewable Energy:** in the form of solar PV coordinated with the electrical panel location and capacity on available south facing roof area. Off site, renewable energy can come in the form of community renewable, Renewable Energy Investment Funds (REIF), Virtual Power Purchase Agreements (VPPA), direct ownership, and Renewable Energy Credits (RECs)

Envelope Targets

Recommendations based on best practices, including the Passive House standard, to meet and exceed the MA Commercial Energy Stretch Code for a ZNC

	Target Ranges	Considerations
Air Tightness	0.06 cfm/ft2 @50PA	<ul style="list-style-type: none"> • Carefully detail air barrier transitions at all envelope intersections, penetrations • Simplify the building envelope
Roof	R-45 to R-55 hr.ft2.F/Btu (whole assembly)	<ul style="list-style-type: none"> • Minimum insulation thickness at roof drains • Minimize thermal bridging at penetrations and transitions
Walls	R-24 to R-28 hr.ft2.F/Btu (whole assembly)	<ul style="list-style-type: none"> • Low embodied energy insulation materials (mineral wool in lieu of foam) • Minimize thermal bridging at cladding attachment • Allow for drying potential with vapor open materials
Slabs	R-12 to R-16 hr.ft2.F/Btu	<ul style="list-style-type: none"> • Low embodied energy insulation materials (EPS in lieu of XPS insulation) • Transition at foundation walls
Floors (cantilevered areas)	R-30 to R-35 hr.ft2.F/Btu	<ul style="list-style-type: none"> • Low embodied energy insulation materials • Thermal bridging at podium structure
Doors	R-2 to R-5 hr.ft2.F/Btu	<ul style="list-style-type: none"> • Air tightness at fire rated doors
Windows	U-0.18 to U-0.22 Btu/hr.ft2.F (whole window) SHGC < 0.38 (COG)	<ul style="list-style-type: none"> • Utilize triple glazed commercial windows with warm edge spacers and thermally broken frames (wood, fiberglass, thermally insulated/gasketed aluminum) • Keep overall window-wall ratio under 40%, preferably ~30%

Building Systems Targets

Recommendations based on best practices, including the Passive House standard, to meet and exceed the MA Commercial Energy Stretch Code for a ZNC

	Description / Component	Target Ranges	Considerations	
Ventilation	Dedicated Outdoor Air System (DOAS) with Energy Recovery Ventilation (ERV)	Sensible Recovery Efficiency (SRE)	> 0.8	<ul style="list-style-type: none"> • Evaluate dual core system as basis of design for high efficiency, low maintenance, and durability • Design for balanced ventilation • Incorporate post-conditioning to neutral conditions
		Fan Power Efficiency	<0.9 W/cfm	
Heating	Ground source heat pump (GSHP) or air source heat pump variable refrigerant flow (VRF) system	Coefficient of Performance (COP)	For GSHP, TBD For VRF: > 2.1 @17F; > 3.5 @47F	<ul style="list-style-type: none"> • Evaluate feasibility of GSHP system considering well locations, heat exchange typology, and possibility of a shared system with the Strand • For roof equipment, consolidate equipment to allow for maximum available roof area for solar PV
Cooling		COP	> 5.0	
DHW	All electric: Electric storage, point-of-use, or heat pump water heater (HPWH)	Efficiency Factor	TBD	<ul style="list-style-type: none"> • Incorporate water reuse strategies, such as rainwater reuse, greywater reuse
	Low flow fixtures	Fixture flow rate		
Lighting	Fixtures	Lighting Power Density	< 0.6 W/sf	<ul style="list-style-type: none"> • Aim for 30% better than current energy code
	Controls	Occupancy Sensors and Daylight Dimming		

page not used

Section 5

Site Options & Test-fits

5.1 Identification of Suitable Sites



SITE KEY

- BCYF (BPS) ●
- BCYF (STAND-ALONE) ●
- POTENTIAL (PRIVATE) ●
- POTENTIAL (CITY-OWNED) ●
- POTENTIAL (STATE-OWNED) ●

As noted in Section 4: Programming, the ideal multi-story BCYF Community Center building program can be accommodated on a site as small as 24,000 sq. ft. A variety of city owned, state owned, and private sites have been identified as potentially suitable for the implementation of new BCYF Community Centers in Charlestown. Feedback from the community survey and community meetings indicated that there was a strong desire to locate the new center on Medford Street adjacent to the current BCYF location. Although the overall goal was to cast as wide a net as possible, many factors contributed to deciding whether a site meets the criteria necessary for a new community center.

A site with proximity to public green space allows the community center to extend programming beyond the walls of the building. In the course of the study, residents and BCYF staff expressed enthusiasm for athletic field space that could be adjacent to the community center. Additionally, picking a site with proximity to existing BCYF Centers would provide access to programs and resources that can't fit in existing spaces available to the community.

Sites with convenient and safe transportation promotes equitable access. Likewise, sites with established pedestrian routes, convenient street crossings, and nearby bike routes promote multi-modal access to community centers. No new visitor parking is included in the building program however, the generated test fits preserve existing parking at the Charlestown High School site or provide a comparable amount of new parking.

While private sites are abundant, they tend to be smaller in size, and require a more complex acquisition process than their public counterparts. Smaller sites typically need to be acquired in groups and consolidated from various owners, adding further complications.

While BCYF Centers provide vital services for

people living nearby, centers are also large buildings and could generate noise from visitors and building equipment. Convenient access to residential areas should be balanced with the scale, proximity and character of abutting properties.

In regards to density, the denser the area, the more people there are within a convenient distance who could benefit from BCYF's services. Denser neighborhoods tend to have fewer available sites, particularly in traditional residential areas where the small lot sizes are not compatible with the minimum lot requirements of a community center.

The expected impacts of climate change on all sites have been considered. Many BCYF Community Centers are sheltering sites in cases of ever more frequent extreme weather events or other emergencies. Flood risk, through increased rainfall and/or sea level rise should be reviewed both for the site itself and for the safe passage to the site from the surrounding neighborhood. The potential impact of sea level rise across Charlestown was reviewed in Section 2.2, as well as in the further analysis of specifically suitable sites.

The timeline of site acquisition could vary greatly depending on the property ownership of the sites. The sites identified for potential use as a new BCYF Center fall into three general categories: city ownership, state ownership, and private ownership.

In general, sites owned by the City of Boston will have the simplest acquisition process with the shortest timeline. Sites owned by the state or sites that include the conversion of park land will require additional regulatory steps and will have a comparatively larger timeline. Privately owned sites, particularly those merging parcels owned by different parties will have the most complex acquisition process and will therefore be expected to have the longest timeline.

5.2 Sites for Community Center Test-Fits



SITE KEY

- POTENTIAL SITE (CITY) ●
- POTENTIAL SITE (PRIVATE) ●
- BCYF (BPS) ▬
- BCYF (STAND-ALONE) ▬
- SCHOOL ●

In order to verify the programming data described in Section 4, this study includes test fitting the program on a particular site. A test-fit is a three dimensional test of the community center uses and activities on a particular site. The test-fit verifies the size and adjacency attributes of the building program and gives a better understanding of the opportunities and constraints of the particular site. **The test-fit is not a design proposal. The test fit is for study purposes only.**

The 150 16th Street parcel is privately owned by Mass General and located on the waterfront along the pedestrian path that connects Menino park. The site is subject to Navy Yard Zoning; Chapter 91, that would require development on the site to provide 61,000 sq.ft of public space.

After a review of multiple sites, two sites; one publicly owned and the other privately owned, were selected for a test-fit. The sites benefit from being near existing public services such as schools, parks, open space, and/or public transit. Each site is intended to demonstrate the range of suitable building locations identified throughout Charlestown in this study.

The Charlestown BCYF on Medford Street currently shares facilities with the connected Charlestown High School. The site is a parking lot and adjacent to outdoor athletic fields. Due to limited parking in the area and the high demand for it, the test fits on this site preserve parking on the ground level. The majority of the site is in a flood risk zone therefore an elevated building over parking brings the benefit of continued access during a climate emergency.

5.3 Test-Fit Sites in Detail

1.1 Charlestown High School Site



Site Area: 24,000 SF

Owner: City of Boston

Owned by the City of Boston, the Charlestown High School Site is currently used as a parking lot for the Charlestown Community center. It's accessed from Terminal Street and is immediately adjacent to the Charlestown High School football field and three outdoor tennis court.

As seen in the 1% 2070 Coastal Flood risk analysis highlighted earlier, the majority of the site is in the high flood risk zone. This consideration shaped our decision to raise the proposed building and limit the amount of programs on the ground to pedestrian lobbies, support and the existing parking lot.

The site has fairly good transportation accessibility, with access to the 93 bus line one block south along Bunker Hill Street. Additionally, there is a blue bikes terminal across the athletic field along Medford Street.

The Charlestown BCYF operates out of Charlestown High Schools' building on 255 Medford St. It uses the High School's athletic and aquatic facilities for BCYF programming.

Two test-fits were generated for this site. The first continues the shared use of the schools' facilities and the second is a complete stand alone facility.

1.1 Charlestown High School Site: Shared Facilities

Building GSF: 25,500 sq ft

The Charlestown High School Site test fit has its entry on Terminal St. Entry lobbies grant easy access to the community room and kitchen, art room and senior center on the first floor. Athletics spaces such as the gym, fitness studios and locker rooms are also on this level. These adajancies are convenient in consolidating larger community programs on the same level.

The second level is occupied by the education and youth programs such as the youth classroom, makerspace and teen center. There is an outdoor terrace by the youth classroom facing Terminal St. to serve as an outdoor play area for teens.

The proximity to the Charlestown High's full 4-court gym and competition pool, allows the new building to have a smaller program with the idea that BCYF and Charlestown High would continue to share facilities. Connector bridges provide community access to the school's facilities directly from the community center without requiring patrons to navigate through the school. A ground level enclosed corridor links the new center to the pool in the school building. A second bridge on the first level provides community access to the full gym in the school building.

Advantages:

- Ideal site size
- Adjacent to residential areas
- Adjacent to existing park, playground, and athletic fields
- Adjacent to existing high school

Disadvantages:

- Located in high flood risk zone
- Not directly accessible by public transportation
- Existing parking should be retained on ground level



1.1 Charlestown High School Site : Shared Facilities



Site



Test fit aerial



1.1 Charlestown High School Site : Shared Facilities



Level 1 Program Diagram



Level 2 Program Diagram



Level 3 Program Diagram

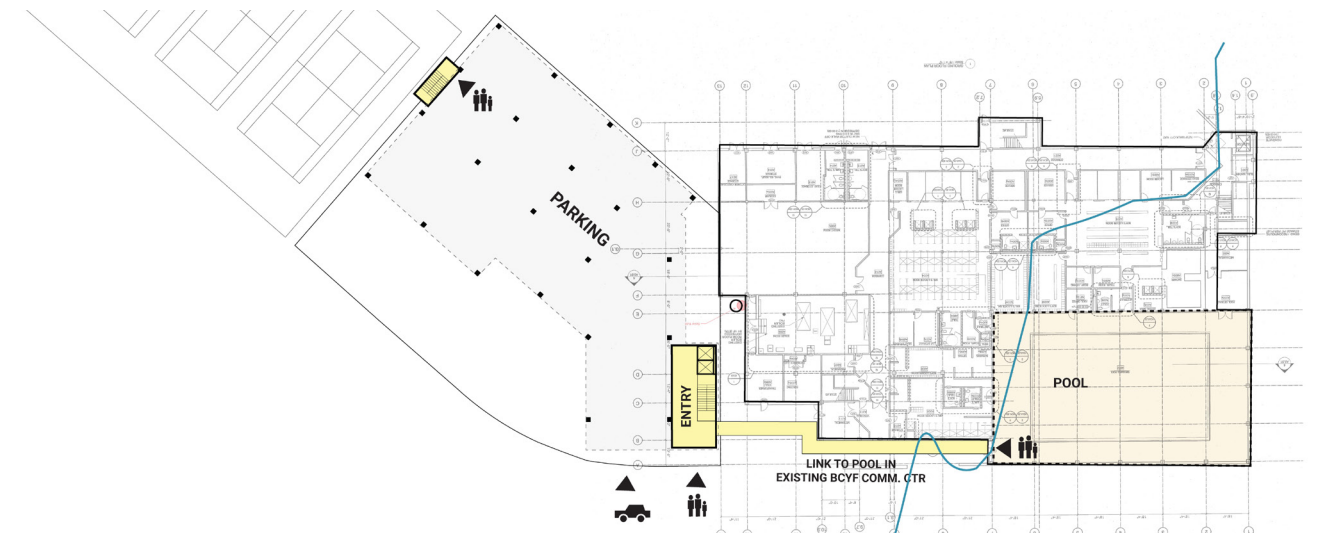

Level 1 Floor Plan

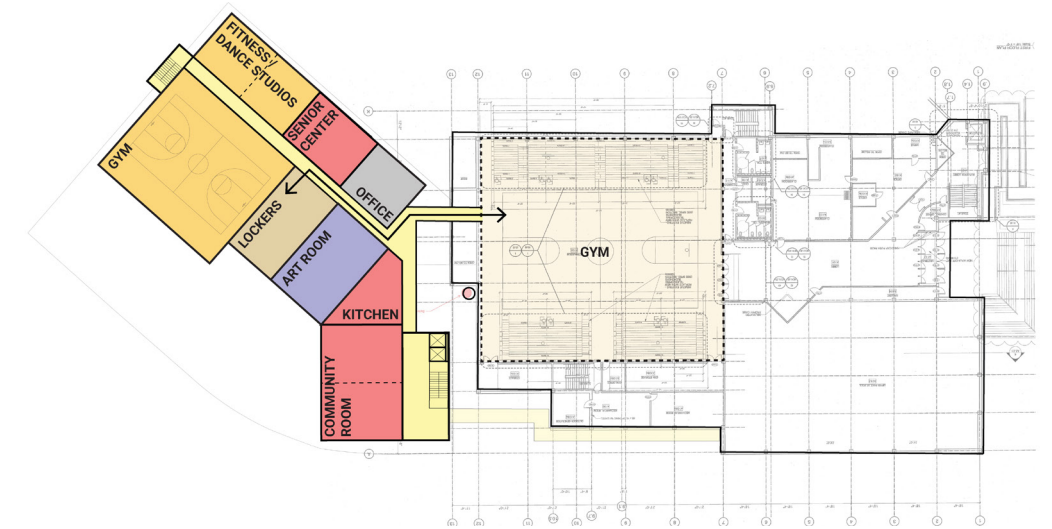

Level 2 Floor Plan

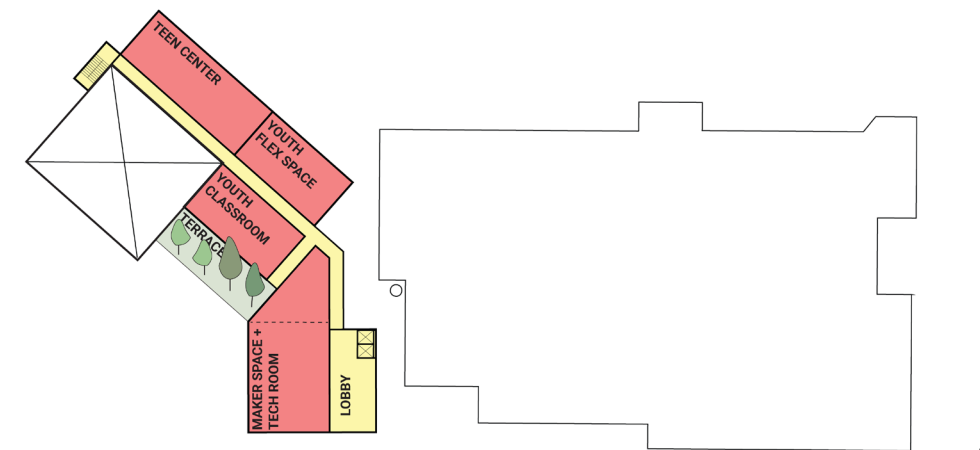

Level 3 Floor Plan



1.2 Charlestown High School Site: Stand Alone

Building GSF: 45,000 sq ft

This test-fit decouples BCYF from its shared facilities relationship with Charlestown High by proposing a stand alone BCYF facility with a full program.

This test fit has its entry on the northern corner of the site along Terminal St. An entry lobby with a feature stair on the ground level grants easy access to the community room and kitchen, senior center, fitness studios, lockers and a competition swimming pool with spectator seating. Similar to the shared facilities test fit, parking is retained on the ground level.

The third level hosts the enrichment programs, youth and teen spaces and spectator seating overlooking the pool below. A full court gym sits on the fourth level with an adjoining terrace offering the possibility for related outdoor activities.

Advantages:

- Ideal site size
- Adjacent to residential areas
- Adjacent to existing park, playground, and athletic fields
- Adjacent to existing high school

Disadvantages:

- Located in high flood risk zone
- Not directly accessible by public transportation
- Larger building
- Existing parking should be retained on ground level



1.2 Charlestown High School Site : Stand Alone



Site



Test fit aerial



1.2 Charlestown High School Site: Stand Alone



Level 1 Program Diagram



Level 3 Program Diagram



Level 2 Program Diagram



Level 4 Program Diagram



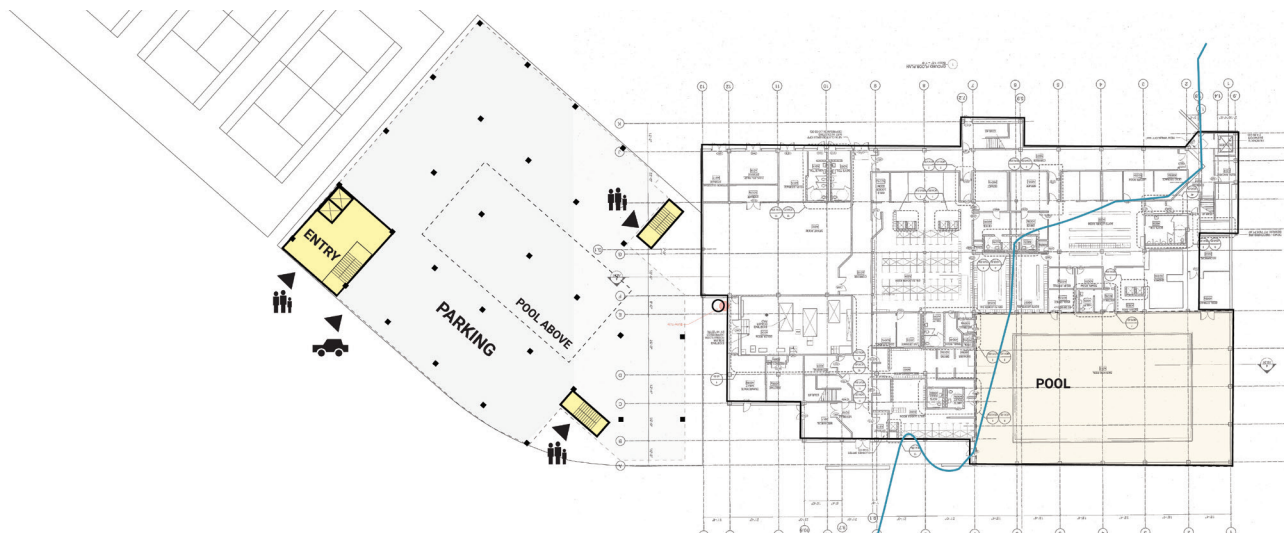

Level 1 Floor Plan

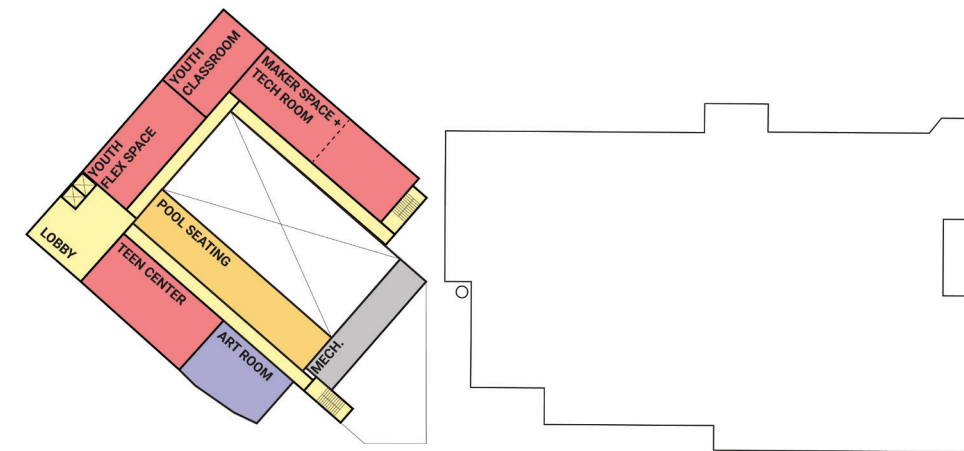

Level 3 Floor Plan

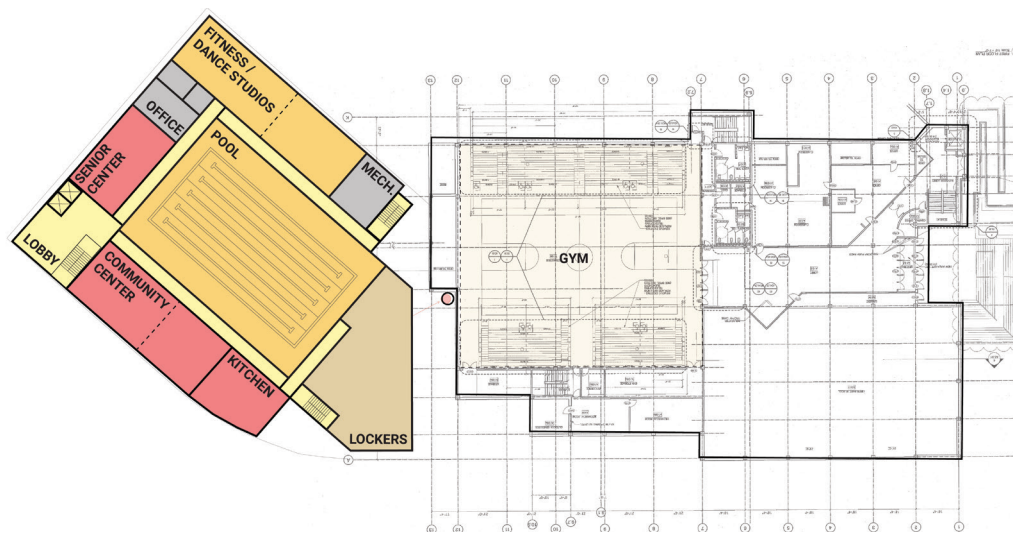

Level 2 Floor Plan

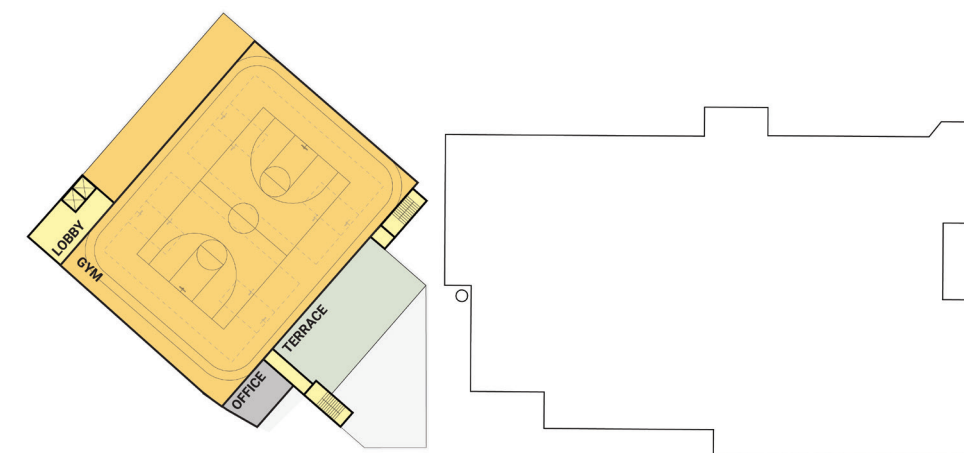

Level 4 Floor Plan



2 Navy Yard/ Spaulding Site



Site Area: 115,000 SF

Owner: Mass. General

The 150 16th St. is a privately owned site. It is located on adjacent to Spaulding Rehabilitation Hospital and fronts the Little Mystic channel. The northern edge of the site has strong views of the iconic Tobin bridge.

The site is undeveloped and sits between Spaulding Rehabilitation Hospital and research labs in the Navy Yard. Menino Park and Barry's Field; two prominent waterfront green spaces in Charlestown are nearby. The Charlestown YMCA is two blocks down along 3rd Ave.

The site is limited in its accessibility to public transit. A single 93 bus line runs along 13th st. one block down SW of the site. The Community College orange line station 1.4 miles away.

Entry to the community center would be on 16th st, across the 5th ave. parking garage. Given the current program, size and shape of the site, the test fit presents a four level building on the site.

2 Navy Yard/ Spaulding Site

Building GSF: 51,000 sq ft

The four-story building bridges the character of the immediate context, with the large Spaulding Rehab facility to the east, large warehouse buildings to the south, labs to the west, and Mystic river to the north.

The entrance to the building would be at the south east corner of the site along 16th st. and provide easy access to the community room and kitchen facilities on the first level. A covered outdoor space would be open to the community to the west of the site along 16th st. On the second level, the fitness center is immediately accessible from the lobby elevator, while the senior center, swimming pool, mechanical space and lockers fill out the rest of the floor. The third level would host community enrichment spaces such as a youth classroom, flex space, makerspace, tech room and an art studio. Access to spectator seating for the swimming pool below would also be on this level. A full court gymnasium and outdoor space sit on the fourth level.

Advantages:

- Large site
- Proximity to public parks and fields
- Limited residential adjacencies

Disadvantages:

- Fully located in flood risk zone
- Limited access to public transit
- Lengthy acquisition process from private owner



2 Navy Yard/ Spaulding Site

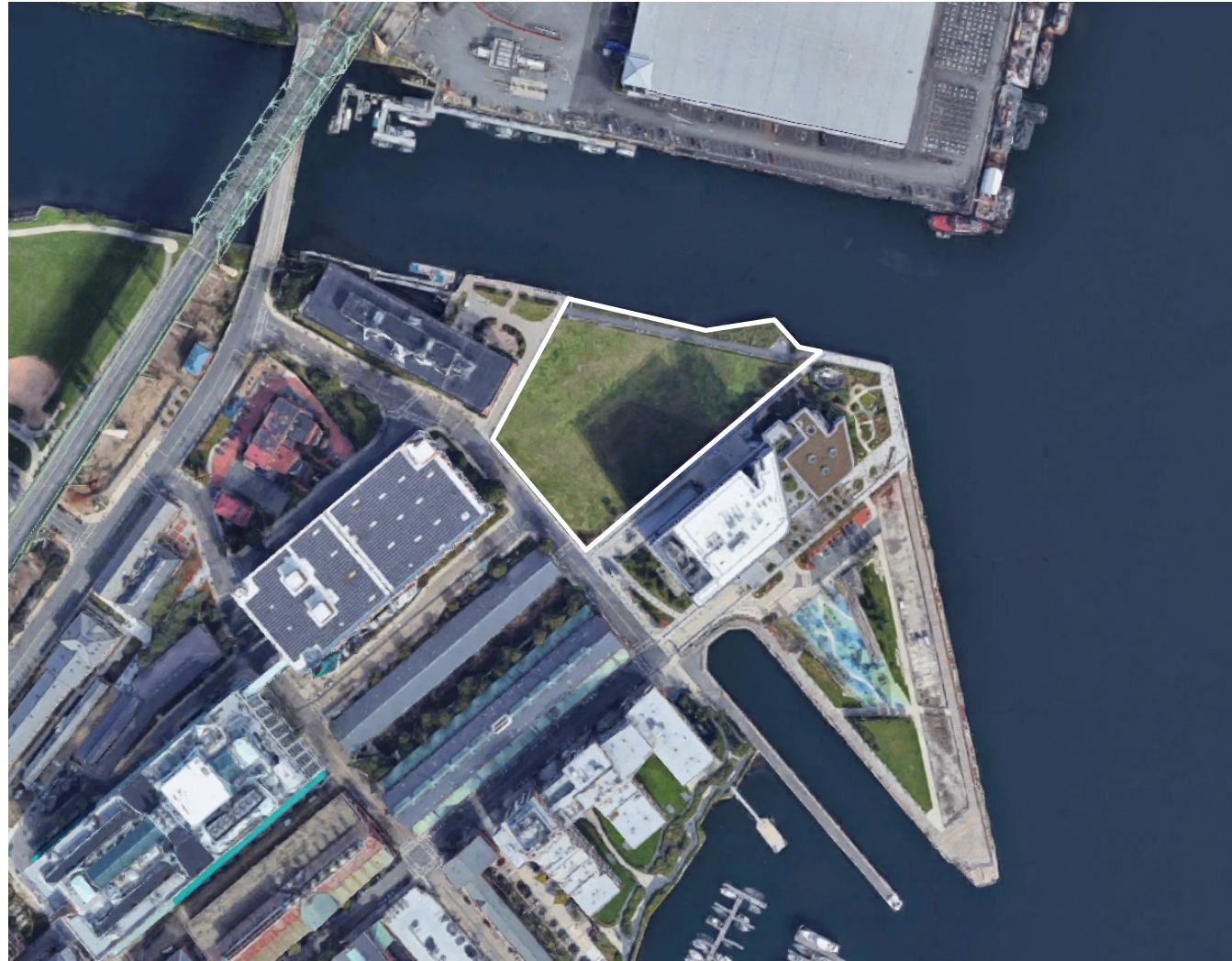

Site

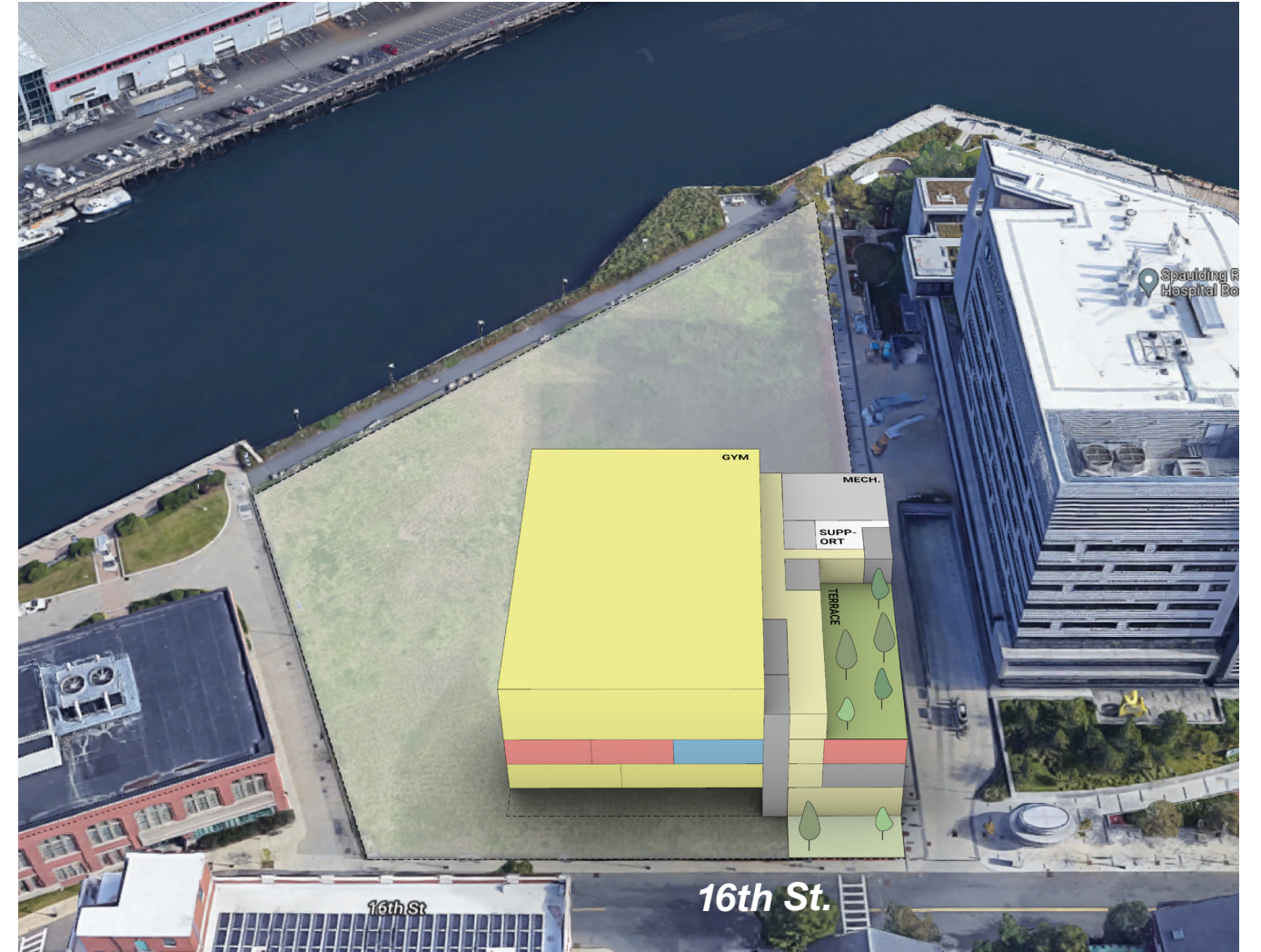

Test fit aerial



2 Navy Yard/ Spaulding Site



Level 1 Program Diagram



Level 3 Program Diagram

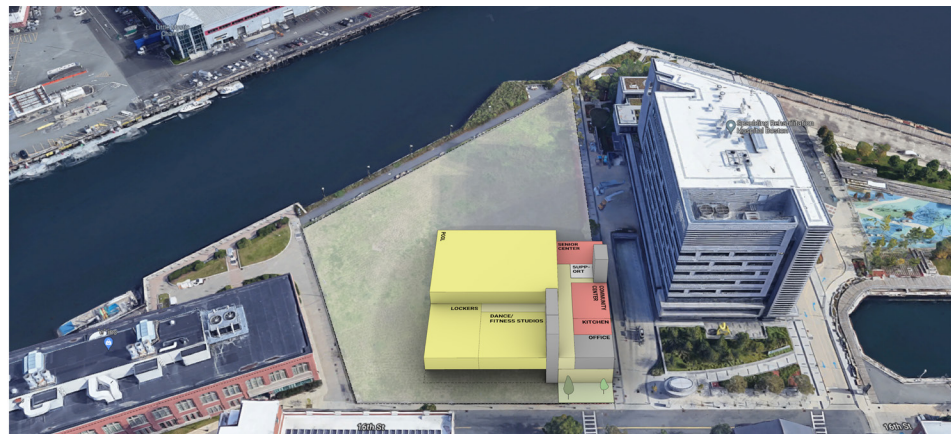

Level 2 Program Diagram

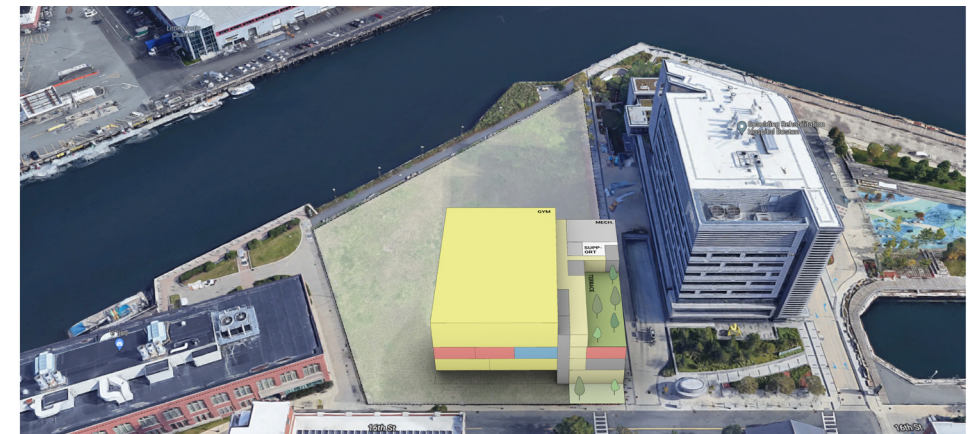

Level 4 Program Diagram



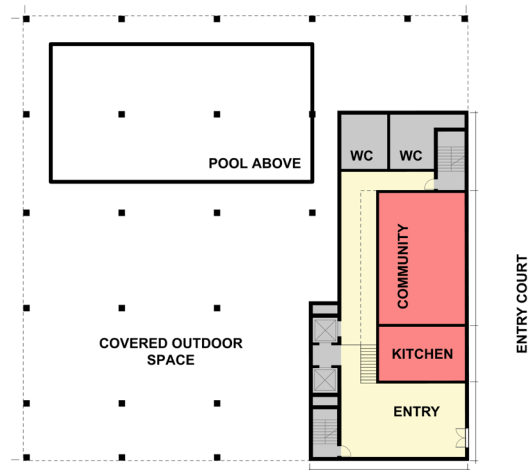

Level 1 Floor Plan

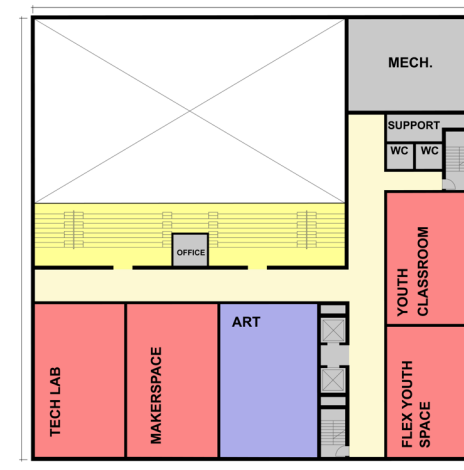

Level 3 Floor Plan

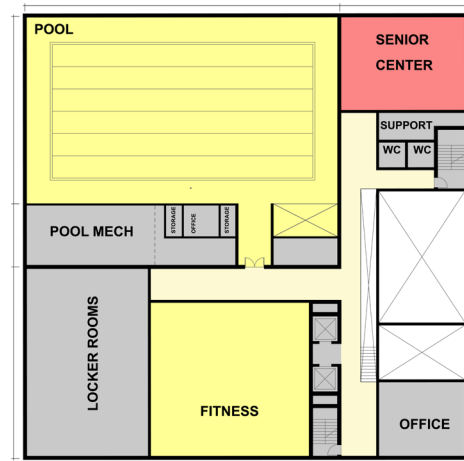

Level 2 Floor Plan

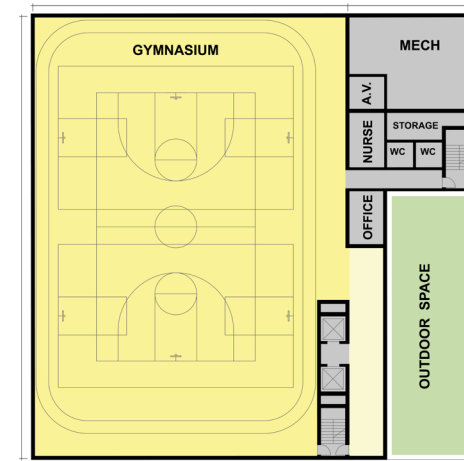

Level 4 Floor Plan



page not used

Appendix A

A.1 Potential Sites: Complete List

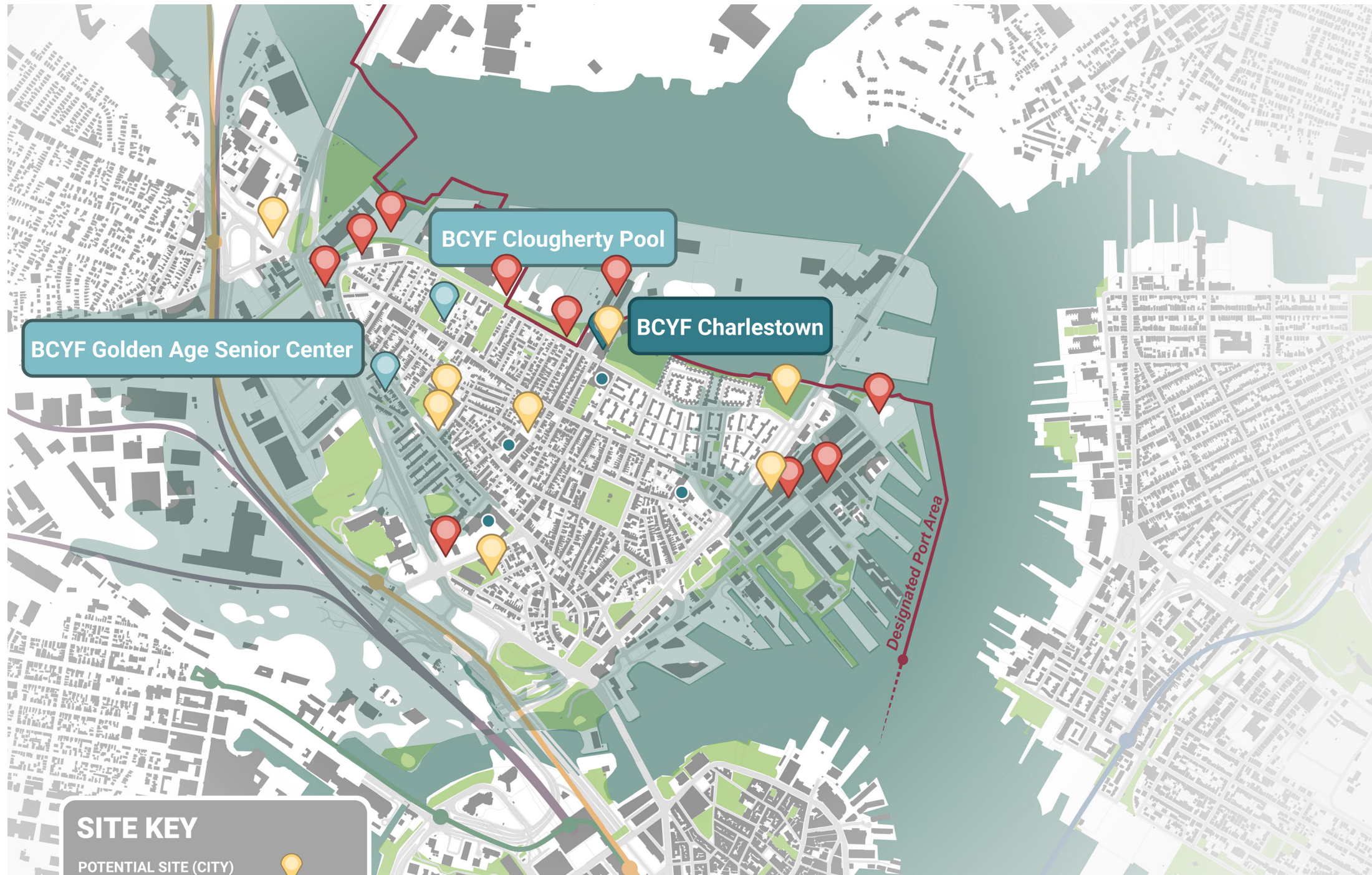

SITE KEY

- POTENTIAL SITE (CITY) 📍
- POTENTIAL SITE (PRIVATE) 📍
- BCYF (BPS) 📍
- BCYF (STAND-ALONE) 📍
- SCHOOL

- | | | |
|--|---|---|
| 
Charlestown High | 
Peter Looney Park | 
Warren Prescott School |
| 
295 Medford Street | 
Yard's End Parcel 7 | 
Navy Yard Building 100 |
| 
Charlestown Commerce Center | 
Barry Park | 
Charlestown YMCA |
| 
500 Main St | 
Schraff's Center I | 
Schraff's Center II |
| 
Navy Yard Building 105 | 
Clarence Edwards Middle School | 
Bunker Hill Mall |
| 
545 Medford Street | 
Sullivan Square: New Parcels | |

Clougherty Pool

Address
331 Bunker Hill Street
Ownership
Public: City of Boston
Area
30,000 sq ft
Current Use
Pool and pool house
Pros & Cons:
<p>Pros: City owned site; Adjacency to exiting playground and park</p> <p>Cons: Will require Article 97 review for building on park area; Must work with landmark status of Olmstead designed Doherty Park.</p> <p>Note: The Clougherty Pool is in the design phase for a complete renovation/ reconstruction.</p>



Charlestown BCYF

Address
255 Medford Street
Ownership
Public: City of Boston
Area
24,000 sq ft
Current Use
Parking lot
Pros & Cons:
<p>Pros: City owned site; Adjacency to existing playing fields provides flexibility for community center programming; Possible connection with existing high school / community center spaces; New center can be built above a parking level to preserve existing parking spaces.</p> <p>Cons: Smaller site requires a multi-floor layout; Within future flood zone.</p>



Peter Looney Park

Address
34 Union Street
Ownership
Public: City of Boston Public: Commonwealth of Mass
Area
26,000 sq ft
Current Use
Small park with tennis court and playground; parking lot
Pros & Cons:
<p>Pros: City owned site; Center could be located on current site of Peter Looney Park, while taking some land from the adjacent site of the O'Neil Memorial Ice Rink; Portion of parking lot could be transformed into new playground / park space next to center and skating facilities</p> <p>Cons: Smaller site requires a multi-floor layout. Requires relocating a popular neighborhood park. Requires Article 97 review.</p>



Warren Prescott School

Address
50 School Street
Ownership
Public: City of Boston
Area
18,000 SF (of 79,000)
Current Use
Elementary school parking lot
Pros & Cons:
<p>Pros: City owned site; Location in the center of Charlestown in a dense area with close adjacent residential uses; New center can be built above a half-basement parking level to preserve existing parking spaces.</p> <p>Cons: Site is absolute minimum size to meet programming needs - gymnasium would take up an entire floorplate; will result in a taller / multi-story building.</p>



500 Main Street

Address
500 Main Street
Ownership
Public: BPDA (EMS Station 15) Private: Main Street Parcels
Area
35,000 SF
Current Use
Empty private lot; small garage facility on Boston Redevelopment Agency site
Pros & Cons:
<p>Pros: Site located at intersection of Charlestown's most prominent streets: Rutherford, Main, Bunker Hill, Medford; Site currently EMS facility and vacant private lot; Across from Fire station, community garden, Charlestown Theater, and small park (strong civic / cultural presence here).</p> <p>Cons: Requires acquisition or private property for sufficiently sized parcel; requires relocation of EMS facility.</p>



Schrafft Business Center II

Address
529 Main Street
Ownership
Private: Schrafft Center LLC
Area
686,000 SF (total incl. water)
Current Use
Schrafft Business Center; Converse Corporate; Bright Horizons; parking
Pros & Cons:
<p>Pros: Located by prominent intersection of Main St, Medford St, and Bunker Hill Street; Waterfront Property with ramp, pier, and boardwalk; Adjacent to Ryan Playground and outdoor athletics facilities.</p> <p>Cons: Site within flood risk zone. New community center would require large portion of property.</p>



Schrafft Business Center I

Address
425 Medford Street
Ownership
Private: Schrafft Center LLC
Area
840,000 SF (total incl. water)
Current Use
Schrafft City Center: Warehouse / distribution
Pros & Cons:
<p>Pros: 1 of 3 Schrafft's owned sites between Medford St and the waterfront; Proposed BPDA plan under review for redevelopment of 425 site and accompanying Schrafft waterfront. Could potentially incorporate new BCYF center into plans for site.</p> <p>Cons: Located within future flood zone. New community center would require large portion of property.</p>



295 Medford Street

Address
295 Medford Street
Ownership
Private: Boston Autoport LLC
Area
39,500 SF
Current Use
Parking lot
Pros & Cons:
<p>Pros: Connection to Mystic Greenway; Potential to act as a buffer between residential and industrial areas; Near existing Charlestown High School athletics facilities.</p> <p>Cons: Within Designated Port Area, will require state legislative action for non-port use.</p>



Yard's End Parcel 7

Address
150 16th Street
Ownership
Private: Mass General
Area
115,000 SF (req'd to provide 61,000 SF for Public use.)
Current Use
Empty grass lot (fenced)
Pros & Cons:
<p>Pros: Waterfront path connects to outdoor space next door and Menino Park; Community center could help future development on site meet public destination requirements for Waterfront Activation Plan.</p> <p>Cons: Waterfront site, partially within flood risk zone; Navy Yard location remote from most residential areas of Charlestown.</p>



page not used

A.2 Shared Facility Test-fit: Building Systems Narratives

The Charlestown Site was selected to examine in greater detail for a buildings systems and cost analysis. The multilevel testfit for the Charlestown High School site is representative of an ideal site size with shared program. The building is elevated to contend with flood risk. It is on the lower end of the cost spectrum in comparison to the stand alone years end tesfit on Parcel 7 referenced in the Cost estimate in Appendix A.3.

Charlestown High School Site



page not used

MEPFP Systems Narrative

Boston Centers for Youth & Families

Programming & Siting Study

Charlestown, MA

Ansul system. The Ansul system shall come as a package with the hood and will NOT be fire protection sub-contractor work.

FIRE PROTECTION SYSTEMS

The new fire protection systems will be supplied via a new underground fire service main connected to the site water main. The new underground fire service main will be brought into the mechanical room. The new fire service will be provided with a new double check valve backflow preventer at its point of entry into the mechanical room. A new wet system alarm valve and sprinkler riser will be provided on the discharge side of the backflow preventer to supply all of the automatic wet pipe sprinkler systems. If required, a new dry system alarm valve and sprinkler riser will also be provided to supply the automatic dry pipe sprinkler systems. The sprinkler systems for each floor of the building will be segregated into separate sprinkler system zones. Each sprinkler system zone will be provided with a shut off valve and a water flow switch. In this way the sprinkler systems of each floor of the building will be on their own separate sprinkler system zone. In the multi-story sprinkler system zone stations for each floor will be located in a connecting egress stair and on each floor landing within the connecting stair. A means will be provided to test all water flow switches. A fire department connection will be located on the outside of the building and at a point of vehicle access. The fire department connection piping will be provided with a check valve in accordance with NFPA-13. The fire department connection will have the ability to charge all of the sprinkler systems and sprinkler system zones in the building. An electric alarm bell will be provided on the outside of the building adjacent to the fire department connection. Due to the height of the building a standpipe system will not be provided.

All sprinkler systems will be designed and installed in accordance with NFPA-13. NFPA-13R may not be used for this project. All control valves will be electrically supervised. All sprinkler systems shall be UL listed and / or FM approved for fire service use. All sprinkler systems and equipment shall be rated at 175 psi working pressure. All sprinkler systems will be designed, tested and installed in accordance with the applicable sections of the Massachusetts State Building Code 9th edition and NFPA-13 latest accepted editions as well as the regulations and guidelines of the local authority. All sprinkler systems shall be designed, tested and installed by a sprinkler contractor licensed and experienced in the state of Massachusetts in the design, installation and testing of automatic fire sprinkler systems.

General use common areas, classrooms, staff support and office areas will be hydraulically calculated per NFPA-13 at a light hazard occupancy, with a design density of .10 gpm per the most remote 1500 square feet. A 100 gpm hose stream allowance will be provided.

Storage, demonstration kitchen and Mechanical areas will be hydraulically calculated per NFPA-13 at an ordinary hazard occupancy group 2, with a design density of .20 gpm per the most remote 1500 square feet and will be provided with a 250 gpm hose stream allowance. The community kitchen shall be equipped with a commercial cooking hood and related

Plumbing Fixtures

The plumbing fixtures shall be all new and shall be water conservation type. Toilets shall be floor mounted, tank type, and shall be 1.28 gpf operation. Bathroom lavatories may be wall mounted with concealed carrier supports or counter mounted. The lavatory faucets shall be 0.5 gpm rated and shall be provided with mixing valves to temper the hot water to a maximum of 110 degrees. Showers, if used, shall be 1.5 gpm rated. Urinals, if used, shall be wall mounted with concealed carrier supports and shall utilize 0.5 gpf flush valves. Kitchen sinks shall be stainless steel counter mounted type with 1.5 gpm rated faucets. Floor drains shall be provided in bathrooms where required by code. ADA plumbing fixtures shall be provided where required and where indicated on the architectural drawings. All plumbing fixtures shall be provided with service stops.

Cold Water

A new 2" domestic water service shall be provided and shall enter the mechanical room. A new shut off valve and water meter will be provided at the new water services point of entry into the existing mechanical room. Cold water distribution to the new plumbing fixtures and equipment will be Type L copper with solder fittings or pressfit fittings. All cold water pipe and fittings shall be provided with pipe insulation. All water piping shall be provided with pipe labels to indicate service.

Hot Water

A new electric storage type water heater(s) shall be provided and shall be located in the mechanical room. The new water heater(s) shall supply hot water for the building plumbing fixtures and equipment. A hot water circulation system with pump and controls will be provided to maintain the water temperature in the hot water piping system. Hot water will be stored at 140 degrees. A 140 degree hot water supply will be provided for the fixtures and equipment in the community kitchen. Mixing valves will be provided for all plumbing fixtures that are not within the community kitchen and that do not require 140 degree hot water. These mixing valves will be set to temper the hot water to a maximum of 120 degrees for hand washing sinks and to 110 degrees for public use bathroom lavatory faucets. Hot water distribution to the new plumbing fixtures and equipment will be Type L copper with solder fittings or pressfit fittings. All hot water supply and circulation pipe and fittings shall be provided with pipe insulation. All water piping shall be provided with pipe labels to indicate service.

Sanitary and Vent

Sanitary and Vent piping systems will be provided for the new plumbing fixtures and drains throughout the building. The plumbing fixtures and drains will be connected to a network of new sanitary piping that work their way down through the floors of the building to below ground. The new underground piping will be collected together and taken out of the building via a new underground sanitary main where it will be connected to the site sanitary sewer system. New vent piping systems will be provided for the plumbing fixtures. The new vent piping systems will be collected together as much as possible above the ceilings and will be taken up through the floors of the building and up through the existing roof at various locations. The sanitary and vent piping system will be new and will be DWV copper and cast iron with stainless steel hubless fittings.

Natural Gas

At this time there are no plans to use natural gas for this project. New equipment will be electric.

Variable Refrigerant Flow Heat Pump Fan Coil Unit

The spaces throughout the building will be provided with heating and cooling by a variable refrigerant volume fan coil units interconnected to heat recovery type variable refrigerant volume heat pumps. Each fan coil unit shall be a horizontal type unit. Each heat pump unit shall be interconnected to the several system fan coil units through an insulated refrigerant piping system and be able to provide simultaneous heating and cooling up to 21 tons of connected fan coil unit capacity. A condensate drain piping system will also be required to transport condensate from each unit to storm drain or to the outdoors.

Supply and return air shall be ducted from the unit to air outlets in each conditioned space. The main supply and return ducts shall be provided with acoustical lining for the first 6 lineal feet from the unit.

Each fan coil unit shall be controlled by a wall mounted programmable thermostat.

Ventilation

Ventilation and exhaust air shall be provided throughout the building with energy recovery unit. New insulated low-pressure air duct systems will provide conditioned ventilation and exhaust air throughout the spaces. The ventilation air shall be ducted to each to fan coil return to provide ventilation. Exhaust air shall be ducted to the space to match the ventilation airflow and provide neutral air pressure.

The energy recovery unit ventilation air shall be heated and cooled with a refrigerant coil, refrigerant and remote heat pump. The heat pump system shall operate to provide neutral air temperature throughout the year.

Classrooms

Heating cooling and ventilation shall be provided with VRF and ERV as mentioned. Local exhaust systems shall be provided for arts and science classrooms through exhaust fan, exhaust ductwork and exhaust registers.

Kitchen

Kitchen grease hood shall be provided with welded steel grease ductwork, grease duct wrap and roof mounted exhaust fan. Make-up air shall be provided through hood PSP, insulated supply ductwork and roof mounted outdoor air ductwork. The make-up air shall be heated from 0-60 degrees F. Kitchen space shall be heated and cooled through the VRF system.

Locker room

Locker room shall be heated and cooled through the VRF system. The space shall be ventilated and exhausted with a dedicated energy recovery unit.

Gymnasium

Heating, cooling and ventilation shall be provided through a roof mounted packaged roof top with electric cooling and electric heating (heat pump). Conditioned air shall be provided throughout the space with galvanized exposed double wall ductwork with fiberglass insulation.

Entries and Vestibules

The entries and vestibules shall be heated and cooled with ductless cassette fan coil units interconnected to heat recovery type variable refrigerant volume heat pumps. Each fan coil unit shall be controlled by a wall mounted programmable thermostat.

Electric Rooms

Electric rooms shall be heated and cooled with ductless wall mounted fan coil units interconnected to heat recovery type variable refrigerant volume heat pumps. Each fan coil unit shall be controlled by a wall mounted programmable thermostat.

Sprinkler Room/Electric Room/Storage Rooms/Miscellaneous Mechanical Rooms

Miscellaneous mechanical rooms shall be heated and cooled with ductless wall mounted fan coil units interconnected to heat recovery type variable refrigerant volume heat pumps. Each fan coil unit shall be controlled by a wall mounted programmable thermostat.

Janitors Closets

Provide base building exhaust systems including exhaust to the janitors with an exhaust air system designed for a minimum of 50 CFM exhaust per closet.

Stairwells

Stairwells shall be heated and cooled with ductless wall mounted fan coil units interconnected to heat recovery type variable refrigerant volume heat pumps. Each fan coil unit shall be controlled by a wall mounted programmable thermostat.

Elevator Machine Rooms

Each elevator machine room shall be vented into the elevator hoistway through a 12"X12" screened opening in accordance with applicable codes. The room shall be provided with a packaged air conditioning unit consisting of a ductless air conditioning unit, remote air cooled condensing unit, interconnecting refrigerant piping and applicable controls to maintain space conditions of 72°F/40% RH.

Building Management Systems

All HVAC system shall be interfaced with a building management system. The building management system shall be provided with all hardware, programming and graphics as needed to monitor and adjust the HVAC systems and setpoints. The building management system shall also provide occupied and unoccupied operating and alarms.

ELECTRICAL SYSTEMS

Electrical systems shall comply with the 527 CMR (Massachusetts Amendments to the 2023 National Electrical Code) and 2021 International Energy Conservation Code.

Electrical Service

The proposed electrical service shall consist of a single service and shall originate from an associated utility pad-mounted transformer. The primary conduits (2-5") shall be provided by the electrical contractor, from a utility riser pole or manhole to the utility provided pad-mounted transformer.

Main Switchgear shall be located within the building's main electric room and consist of a 2000Amp, 120/208Volt, 3-Phase, 4-Wire switchgear; lineup shall contain a 2000Amp main circuit breaker/current transformer enclosure and associated distribution section(s) for all areas. 120/208Volt panelboards shall be provided throughout the building for general power purposes.

Electronic trip circuit breakers with arc energy reduction in accordance with NEC 240.87 shall be provided for all circuit breakers rated 1,200 Amps or higher.

General Power

General purpose power receptacles shall be provided in all common areas. Receptacles shall be provided in corridors every fifty-feet maximum for general maintenance use and within twenty-five feet of all HVAC equipment per NEC 210.63. Provide all power connections for power-assist automatic door openers, HVAC equipment and elevator(s) including disconnects and circuit breakers.

Community Kitchen

The kitchen shall be provided with a dedicated panelboard located within the space. The equipment under the hood shall be connected to a shunt-trip relay panel which will be shut down during the activation of the hood fire suppression system. The remainder of the kitchen equipment shall be connected to independent kitchen panels with main breakers. All single-phase receptacles rated 150 Volts to ground or less, 50 Amps or less and three-phase receptacles rated 150 Volts to ground or less, 100 Amps or less shall be provided with ground-fault circuit-interrupter protection for personnel.

Photovoltaic System

Provisions for future solar array shall be provided including conduit path from main electric room to roof, circuit breaker within house/common area main switchgear, bussing within switchgear and associated disconnects to accommodate the system as required. Circuit breaker size and bussing shall be coordinated with solar design as the design progresses.

Electrical Vehicle Charging

Determination will need to be made by the owner as to the number of electric Vehicle charging stations that will be required for the site and the type of charging desired. The current load calculations account eight (8) charging stations. If additional stations are requested, it may have an impact on the service size, voltage and distribution.

Generator

A generator is not required per code, but if the City of Boston would like to utilize the proposed building as a "shelter in place" facility, a stand-by generator may be provided. The generator shall be sized to accommodate the proposed shelter area with a sound attenuated enclosure and seventy-two (72) hour diesel sub-base fuel storage tank. Similarly sized

Automatic Transfer Switch shall be provided accordingly. Final generator size and associated electrical characteristics to be coordinated as the design progresses.

Fire Alarm

A complete addressable fire alarm system with voice evacuation shall be provided for each building in accordance with NFPA 72 National Fire Alarm Code, Massachusetts State Building Code, Fire Protection and Life Safety Systems, ADA and all local codes and bylaws for Life Safety and Fire Alarm.

The system shall consist of an addressable fire alarm control panel with voice evacuation, microphone(s), remote annunciator, notification to the Fire Department, manual pull stations within five-feet of all exit doors, on each floor and shall not exceed a travel distance of two-hundred feet on the same floor, system smoke detectors shall be provided for the common areas: locate thirty-feet on center in lobby areas and corridors, provide detectors in all electrical/tele/data rooms, elevator machine room (*multi-story building option*) and at all control panels, annunciators or fire alarm terminal boxes; provide heat detectors in all mechanical rooms, duct-smoke detectors with remote test stations for all HVAC air systems rated 2,000 CFM or more. Smoke detectors shall be provided at all elevator lobbies within the multi-story building and shall be connected for elevator recall. Tamper, flow and pressure switches are being provided to accommodate the new sprinkler systems. The tamper and flow switches shall be connected to the Fire Alarm Control Panel via addressable modules. Provide audible/visual notification (speaker/strobe) device coverage throughout the facility, including weatherproof devices within the garage, that meet the requirements of NFPA and ADA. Utilize strobe only devices in public bathrooms and other small rooms where ample audible notification is present. System shall include interconnection with the kitchen hood suppression system. System batteries shall provide for twenty-four hours of operation followed by a sixty-minute ring down. Battery calculations shall be submitted by the Electrical Contractor with the cut sheets and drawings to the fire department for review and approval. Knox Box key boxes shall be provided at each building's main entrance annunciator location.

Two (2) in-building emergency responder radio communications systems (Bi-Directional Amplifier) shall be provided as required to improve radio signal strength for both the fire and police departments. A two-hour rated room and enclosed shaft will be required to house the amplifier and for antenna cabling. Contingent upon the frequency used by each department and approval by the local Authority Having Jurisdiction, a single system may be installed in lieu of separate systems.

Lighting

Lighting shall consist of LED energy-efficient fixtures with electronic drivers. Storage areas, electrical, mechanical and utility areas shall be provided with strip fixtures with wire cages. Hallways shall be provided with recessed downlights and wall-mounted sconces. Lobby, classroom and other public spaces will be provided with decorative pendant fixtures, surface, ceiling and wall decorative fixtures. The Gymnasium shall be provided with suspended high-bay type fixtures. Parking garage shall be provided with linear vaporlume wet location type fixtures. Community kitchen shall be provided with lensed and gasketed fixtures. Offices shall be provided with recessed direct/indirect fixtures. The lighting design shall meet the requirement of 2015 IECC, ASHRAE 90.1-2013. Lighting controls for each space shall be designed to employ automatic control methods such as vacancy control, daylight harvesting and manual dimming to meet current Energy Codes while still meeting the demands of the programs for each space.

Exterior Lighting

Exterior Lighting shall be installed to provide lighting levels as recommended by the Illuminating Engineering Society (I.E.S.). Pole mounted fixtures, shall contain LED modules and be decorative in nature with interior directional shields. All

luminaires shall have a total cutoff of all light at less than ninety degrees from vertical (fully shielded). Reflectors of proper I.E.S. distribution shall be selected for maximum efficiency, and shall provide total cutoff of all light at the property lines. Pole heights shall not exceed twenty-feet in height. Light poles utilized for walkway lighting shall not exceed twelve-feet in height. All exterior lights shall have a maximum initial horizontal foot-candle level of eight foot-candles, as measured directly below the luminaires at grade.

Exterior fixtures shall be controlled by a combination of timeclock and photocells. Photocells shall turn fixtures on, and a programmable timeclock shall be provided to turn off, at a designated time.

Exit and Emergency Lighting

Emergency lighting shall be provided to meet Life Safety Code NFPA 101 and MSBC 780 CMR Articles 1006 and 1011. Exit signs shall be LED edge-lit types, red in color, at all exits and as required to direct all occupants out of the building. Emergency lighting shall be provided by wall/ceiling mounted emergency battery units to achieve a minimum of one (1) foot-candle along all exit egresses.

Telephone and Cable Television

A complete telephone system shall be provided, including two (2) four-inch conduits into the building from telephone and CATV manholes or utility poles, ¾" thick plywood backboard for mounting telephone and CATV company-equipment, dedicated quadplex receptacles, provide two (2) four-inch riser conduits with telephone and CATV junction boxes at each floor. All common area outlets shall be installed with terminations, device boxes, conduit as required and wiring back to patch panels located on the corresponding floors. Cable shall be category-6 cabling for all telephone/data outlets and RG-6 cable for CATV outlets.

Two-Way Communication System

The building will be provided with a two-way communication system at the elevator lobby consisting of a main lobby relay card cabinet, amplifiers, area stations on each floor level, transformers, wiring as necessary. System shall be equal to Housing Devices, catalog No.: HDI-ADA-100A, HDI-CB, HDI-ADA-35, HDI-ADA-PS, HDI. Cabling shall be equal to Belden cable 9554, CSC19595MH, WEST PENN 3753.



BCYF Community Center Study Charlestown

March 10, 2023

BASIS OF DESIGN – STRUCTURAL NARRATIVE

GENERAL

- A geotechnical investigation has not been completed, but it is assumed that the building will be supported on a deep foundation system with specific systems to be determined based off recommendations from a geotechnical engineer.
- The building will be a three-story addition to the existing BCYF Community Center. The majority of program space will be on upper levels above parking.
- It is assumed that the scope of work in the existing BCYF Community Center will be limited and will not trigger a seismic upgrade.

STRUCTURAL SYSTEMS

- The Level 1 structure will consist of the following elements:
 - Columns supported by pile caps and deep foundations
 - 6” concrete slab on grade at interior program, including entry, link to existing pool, and stair tower. Parking to be asphalt.
 - 12” perimeter concrete frost walls and grade beams spanning between pile caps, 4’-0” below grade.
 - Pile supported mat foundations to support concrete cores.
- The Level 2 and 3 structure will consist of the following elements:
 - Steel framing with concrete slab on metal deck at Level 2 and 3.
 - Bay sizes are approximately 33’x30’
 - Structure supporting gymnasium to be designed for vibration criteria.
 - It is recommended that a vibration consultant be contracted to develop building specific vibration criteria
 - Depressed structure at Level 3 accessible green roof. To be designed for planting bed and small trees.
 - Lateral system will consist of cast in place concrete shear walls.
 - A seismic separation joint is required between the new addition and existing building, including at links and connection bridges.
- The Roof structure will consist of the following elements:
 - Open web steel joist roof framing at gymnasium roof with concrete slab on metal deck to support a ballasted PV array. Joists to be supported by steel beams and columns at the perimeter. Alternatively, longer span conventional steel framing may be provided at gym roof.
 - Steel framing with concrete slab on metal deck at remainder of roof with capacity to support a ballasted PV array
 - Lateral system will consist of cast in place concrete shear walls.

page not used

A.3 Test fit Cost Estimates

This section includes concept design costs for the 3 test fit options presented earlier in this report. The cost estimates are based on the test-fit design and building systems analysis that was performed as part of this study as well as a test fit design and building systems analysis that was performed for a very similar BCYF facility at the Devine Rink site studied in the BCYF Dorchester Programming & Siting study.

A soft cost estimate for furniture, fixtures, and equipment was generated based on this comparable facility. The cost numbers are escalated to reflect a Q3 2027 construction start with a 24 month construction duration.

For reference, detailed hard cost estimates of the Charlestown High School Shared Facilities Option and the BCYF Dorchester Devine Rink Site are included in appendix sections A3 and A4 respectively

CHARLESTOWN HIGH SCHOOL SITE - SHARED FACILITY

HARD COST ESTIMATE*

CHARLESTOWN HIGH SCHOOL SITE - SHARED FACILITY	\$36,776,701
FF&E ESTIMATE (includes 15% design contingency)	
Community rooms, senior/teen/youth rooms, lobby, offices, fitness rooms	\$400,000
Makerspace equipment	\$180,000
AV equipment	\$430,000
IT and computer equipment	\$1,450,000
SOFT COST TOTAL	\$2,460,000
TOTAL HARD COST	\$39,236,701

(This estimate includes hard costs and FF&E costs only. The estimated Total Project Cost using margins, adjustments and soft costs specific to City of Boston municipal projects will be prepared separately by the Public Facilities Department.)

*see following pages for a full breakdown of the hard cost estimate

NAVY YARD/ SPAULDING SITE OPTION

HARD COST ESTIMATE*

YEAR'S END PARCEL 7 SITE - LESS ESCALATION <small>(based on BCYF Dorchester Devine Rink Siting study)</small>	\$46,085,171
Escalation to Q3 2027	35% \$16,129,810
TOTAL	\$62,214,981
FF&E ESTIMATE (includes 15% design contingency)	
Community rooms, senior/teen/youth rooms, lobby, offices, fitness rooms	\$400,000
Makerspace equipment	\$180,000
AV equipment	\$430,000
Pool	\$30,000
IT and computer equipment	\$1,450,000
SOFT COST TOTAL	\$2,490,000
TOTAL HARD COST	\$64,704,981

(This estimate includes hard costs and FF&E costs only. The estimated Total Project Cost using margins, adjustments and soft costs specific to City of Boston municipal projects will be prepared separately by the Public Facilities Department.)

*see following pages for a full breakdown of the hard cost estimate

CHARLESTOWN HIGH SCHOOL SITE - STAND ALONE FACILITY

HARD COST ESTIMATE*

CHARLESTOWN HIGH SCHOOL SITE - STAND ALONE FACILITY <small>(based on BCYF Dorchester Devine Rink Siting study)</small>	\$46,085,171
Escalation to Q3 2027	35% \$16,129,810
TOTAL	\$62,214,981
FF&E ESTIMATE (includes 15% design contingency)	
Community rooms, senior/teen/youth rooms, lobby, offices, fitness rooms	\$400,000
Makerspace equipment	\$180,000
AV equipment	\$430,000
Pool	\$30,000
IT and computer equipment	\$1,450,000
SOFT COST TOTAL	\$2,490,000
TOTAL HARD COST	\$64,704,981

(This estimate includes hard costs and FF&E costs only. The estimated Total Project Cost using margins, adjustments and soft costs specific to City of Boston municipal projects will be prepared separately by the Public Facilities Department.)

*see following pages for a full breakdown of the hard cost estimate

**BCYF COMMUNITY CENTER -
CHARLESTOWN**
CONCEPT DESIGN COST ESTIMATE - REVISION 1



LOCATION SUMMARY

GFA: Gross Floor Area
Rates Current At February 2023

Ref	Location	GFA SF	GFA \$/SF	Total Cost \$
B	CHARLESTOWN HIGH SCHOOL SITE - SHARED FACILITY OPTION	23,936	890.95	21,325,870
ESTIMATED NET COST		23,936	890.95	21,325,870
MARGINS & ADJUSTMENTS				
	General Conditions / Requirements	12.0 %		2,559,104
	Bonds and Insurances	2.5 %		597,124
	Overhead and Profit	4.5 %		1,101,694
	Construction Contingency			Excl.
	Design / Estimating Contingency	15.0 %		3,837,569
Subtotal (excl. Escalation)		23,936	1,229.17	29,421,361
	Escalation to Mid-Point of Construction (Q3 2027)	25.0 %		7,355,340
ESTIMATED TOTAL COST		23,936	1,536.46	36,776,701

**BCYF COMMUNITY CENTER -
CHARLESTOWN**
CONCEPT DESIGN COST ESTIMATE - REVISION 1



LOCATION DIVISIONS/ELEMENTS SUMMARY

B Building & Sitework

GFA: 23,936 SF Cost/SF: 890.95
Rates Current At February 2023

Ref	Description	%	GFA \$/SF	Total Cost \$
02	Existing Conditions			
F2020	Hazardous Components Abatement		1.67	40,000
	02 - Existing Conditions		1.67	40,000
03	Concrete			
A1010	Standard Foundations		4.81	115,090
A1020	Special Foundations		40.11	960,000
A1030	Slab on Grade		1.51	36,220
A2020	Basement Walls		6.34	151,740
B1010	Floor Construction		17.31	414,243
B1020	Roof Construction		7.06	169,080
C1010	Partitions		5.47	130,910
C1030	Fittings		0.21	5,000
	03 - Concrete		82.82	1,982,283
05	Metals			
B1010	Floor Construction		66.22	1,584,958
B1020	Roof Construction		45.85	1,097,572
C1030	Fittings		14.08	337,030
C2010	Stair Construction		15.07	360,750
	05 - Metals		141.22	3,380,310
06	Wood, Plastics, and Composites			
C1030	Fittings		2.00	47,872
E2010	Fixed Furnishings		13.34	319,357
	06 - Wood, Plastics, and Composites		15.34	367,229
07	Thermal and Moisture Protection			
A1030	Slab on Grade		0.48	11,591
A2020	Basement Walls		0.35	8,410
B1010	Floor Construction		10.84	259,362
B1020	Roof Construction		2.94	70,450
B2010	Exterior Walls		150.00	3,590,505
B3010	Roof Coverings		28.91	692,030
C1030	Fittings		2.50	59,840
	07 - Thermal and Moisture Protection		196.03	4,692,188

BCYF COMMUNITY CENTER - CHARLESTOWN

CONCEPT DESIGN COST ESTIMATE - REVISION 1



LOCATION DIVISIONS/ELEMENTS SUMMARY

B Building & Sitework (continued)

GFA: 23,936 SF Cost/SF: 890.95
Rates Current At February 2023

Ref	Description	%	GFA \$/SF	Total Cost \$
08	Openings			
B2010	Exterior Walls		62.66	1,499,800
B2030	Exterior Doors		1.19	28,500
C1010	Partitions		4.00	95,744
C1020	Interior Doors		7.01	167,712
C1030	Fittings		1.69	40,500
	08 - Openings		76.55	1,832,256
09	Finishings			
B2010	Exterior Walls		15.13	362,076
C1010	Partitions		20.88	499,684
C2020	Stair Finishes		0.41	9,895
C3010	Wall Finishes		17.00	406,852
C3020	Floor Finishes		22.42	536,608
C3030	Ceiling Finishes		16.99	406,580
	09 - Finishings		92.82	2,221,695
10	Specialties			
C1010	Partitions		2.95	70,600
C1030	Fittings		6.32	151,164
	10 - Specialties		9.26	221,764
11	Equipment			
E1010	Commercial Equipment		2.01	48,000
E1020	Institutional Equipment		0.88	21,000
E1090	Other Equipment		3.82	91,360
	11 - Equipment		6.70	160,360
12	Furnishings			
E2010	Fixed Furnishings		6.30	150,732
E2020	Movable Furnishings			Excl.
	12 - Furnishings		6.30	150,732
14	Conveying Equipment			
D1010	Elevators & Lifts		19.64	470,000
	14 - Conveying Equipment		19.64	470,000
21	Fire Suppression			
D4010	Sprinklers		8.00	191,488

BCYF COMMUNITY CENTER - CHARLESTOWN

CONCEPT DESIGN COST ESTIMATE - REVISION 1



LOCATION DIVISIONS/ELEMENTS SUMMARY

B Building & Sitework (continued)

GFA: 23,936 SF Cost/SF: 890.95
Rates Current At February 2023

Ref	Description	%	GFA \$/SF	Total Cost \$
D4090	Other Fire Protection Systems		0.79	19,000
	21 - Fire Suppression		8.79	210,488
22	Plumbing			
D2010	Plumbing Fixtures		3.50	83,776
D2020	Domestic Water Distribution		9.00	215,424
D2030	Sanitary Waste		10.00	239,360
D2040	Rain Water Drainage		2.50	59,840
D2090	Other Plumbing Systems		3.06	73,140
	22 - Plumbing		28.06	671,540
23	Heating, Ventilating, and Air Conditioning			
D3010	Energy Supply		27.61	660,975
D3040	Distribution Systems		17.65	422,476
D3050	Terminal & Package Units		23.94	572,936
D3060	Controls & Instrumentations		8.00	191,488
D3070	Systems Testing & Balancing		2.00	47,872
D3090	Other HVAC Systems & Equipment		7.94	190,000
	23 - Heating, Ventilating, and Air Conditioning		87.14	2,085,747
26	Electrical			
D5010	Electrical Service & Distribution		19.31	462,232
D5020	Lighting and Branch Wiring		17.79	425,719
D5090	Other Electrical Systems		4.42	105,824
G4010	Electrical Distribution		6.79	162,500
G4020	Site Lighting		3.01	72,000
	26 - Electrical		51.31	1,228,275
27	Communications			
D5030	Communications & Security		6.00	143,616
	27 - Communications		6.00	143,616
28	Electronic Safety and Security			
D5030	Communications & Security		7.50	179,520
	28 - Electronic Safety and Security		7.50	179,520
31	Earthwork			
A1010	Standard Foundations		1.66	39,655
A1030	Slab on Grade		0.34	8,236

BCYF COMMUNITY CENTER - CHARLESTOWN

CONCEPT DESIGN COST ESTIMATE - REVISION 1



LOCATION DIVISIONS/ELEMENTS SUMMARY

B Building & Sitework (continued)

GFA: 23,936 SF Cost/SF: 890.95
Rates Current At February 2023

Ref	Description	%	GFA \$/SF	Total Cost \$
G1010	Site Clearing		3.55	85,025
G1020	Site Demolition and Relocations		3.38	81,007
G1030	Site Earthwork		2.29	54,694
G1040	Hazardous Waste Remediation			Excl.
	31 - Earthwork		11.22	268,617
32	Exterior Improvements			
G2020	Parking Lots		8.45	202,250
G2030	Pedestrian Paving		2.80	67,000
G2040	Site Development		4.18	100,000
G2050	Landscaping		1.04	25,000
	32 - Exterior Improvements		16.47	394,250
33	Utilities			
G3010	Water Supply		4.18	100,000
G3020	Sanitary Water		3.13	75,000
G3030	Storm Sewer		18.80	450,000
	33 - Utilities		26.11	625,000
BUILDING & SITEWORK			890.95	21,325,870

BCYF COMMUNITY CENTER - CHARLESTOWN

CONCEPT DESIGN COST ESTIMATE - REVISION 1



LOCATION DIVISIONS/ELEMENTS SUMMARY

B Building & Sitework (continued)

GFA: 23,936 SF Cost/SF: 890.95
Rates Current At February 2023

Ref	Description	%	GFA \$/SF	Total Cost \$
MARGINS & ADJUSTMENTS				
	General Conditions / Requirements	12.0 %		2,559,104
	Bonds and Insurances	2.5 %		597,124
	Overhead and Profit	4.5 %		1,101,694
	Construction Contingency			Excl.
	Design / Estimating Contingency	15.0 %		3,837,569
Subtotal (excl. Escalation)			1,229.17	29,421,361
	Escalation to Mid-Point of Construction (Q3 2027)	25.0 %		7,355,340
ESTIMATED TOTAL COST			1,536.46	36,776,701

BCYF COMMUNITY CENTER - CHARLESTOWN

CONCEPT DESIGN COST ESTIMATE - REVISION 1



LOCATION DIVISIONS/ELEMENTS ITEM
B Building & Sitework

GFA: 23,936 SF Cost/SF: 890.95
Rates Current At February 2023

Ref	Description	Unit	Qty	Rate \$	Total Cost \$
02	EXISTING CONDITIONS				
F2020	Hazardous Components Abatement				
388	Hazardous materials allowance	LS	1.0	40,000.00	40,000
	F2020 - Hazardous Components Abatement			1.67/SF	40,000
	02 - EXISTING CONDITIONS			1.67/SF	40,000
03	CONCRETE				
A1010	Standard Foundations				
59	Cast-in place concrete perimeter strip footing	LF	437.0	125.00	54,625
60	Cast-in place concrete isolated spread footing	EA	37.0	900.00	33,300
317	Cast-in place concrete grade beams, tie-beams, etc	SF	1,811.0	15.00	27,165
	A1010 - Standard Foundations			4.81/SF	115,090
A1020	Special Foundations				
63	Precast piles, 100' deep (assumes 24 no.)	LF	2,400.0	400.00	960,000
	A1020 - Special Foundations			40.11/SF	960,000
A1030	Slab on Grade				
72	Cast-in-place concrete slab on grade	SF	1,811.0	20.00	36,220
	A1030 - Slab on Grade			1.51/SF	36,220
A2020	Basement Walls				
62	Cast-in place concrete foundation wall	SF	1,529.0	60.00	91,740
76	Cast-in-place elevator pit	EA	2.0	30,000.00	60,000
	A2020 - Basement Walls			6.34/SF	151,740
B1010	Floor Construction				
366	Cast-in-place concrete two-way flat slab (incl. slab, columns, drop-panels, etc) (none indicated)	SF	17,877.0		Excl.
77	Cast-in-place concrete topping slab to metal deck	SF	21,534.0	12.00	258,408
84	Premium at first floor pool (none indicated)	SF	7,454.0		Excl.
308	Acoustically isolated slab at elevated Gymnasium	SF	3,463.0	45.00	155,835
	B1010 - Floor Construction			17.31/SF	414,243
B1020	Roof Construction				
78	Cast-in-place concrete topping slab to metal deck	SF	14,090.0	12.00	169,080
	B1020 - Roof Construction			7.06/SF	169,080

BCYF COMMUNITY CENTER - CHARLESTOWN

CONCEPT DESIGN COST ESTIMATE - REVISION 1



LOCATION DIVISIONS/ELEMENTS ITEM
B Building & Sitework (continued)

GFA: 23,936 SF Cost/SF: 890.95
Rates Current At February 2023

Ref	Description	Unit	Qty	Rate \$	Total Cost \$
C1010	Partitions				
79	12" Thick reinforced shear wall (stair/elevator shafts)	SF	2,014.0	65.00	130,910
	C1010 - Partitions			5.47/SF	130,910
C1030	Fittings				
114	Concrete equipment pads, curbs, etc	LS	1.0	5,000.00	5,000
	C1030 - Fittings			0.21/SF	5,000
	03 - CONCRETE			82.82/SF	1,982,283
05	METALS				
B1010	Floor Construction				
80	Structural steel floor framing, assumes 15 lbs/SF	T	161.500	5,500.00	888,250
361	Isolated steel support at Gym enclosure, assumes 10 lbs/SF	T	17.760	5,500.00	97,680
81	Metal floor deck	SF	21,534.0	11.00	236,874
82	Shear studs	EA	3,589.0	6.50	23,329
83	Miscellaneous steel, plates, and connections	T	16.150	5,500.00	88,825
389	Premium for bridge at exst. double-height interior space	LS	1.0	250,000.00	250,000
	B1010 - Floor Construction			66.22/SF	1,584,958
B1020	Roof Construction				
85	Structural steel roof framing, assumes 20 lbs/SF	T	140.900	5,500.00	774,950
208	Structural steel rooftop dunnage	LS	1.0	50,000.00	50,000
86	Metal roof deck	SF	10,540.0	11.00	115,940
89	Metal roof deck, acoustic (Gymnasium)	SF	3,551.0	18.00	63,918
87	Shear studs	EA	2,349.0	6.50	15,269
88	Miscellaneous steel, plates, and connections	T	14.090	5,500.00	77,495
	B1020 - Roof Construction			45.85/SF	1,097,572
C1030	Fittings				
115	Painted metal guardrail (egress stairs)	LF	52.0	275.00	14,300
116	Painted metal handrail (egress stairs)	LF	85.0	150.00	12,750
117	Decorative railing system (void, circulation stairs, etc)	LF	180.0	500.00	90,000
223	Structural steel support, operable wall	LF	59.0	400.00	23,600
224	Structural steel support, gymnasium divider	LF	55.0	400.00	22,000
225	Structural steel support, overhead backstops	EA	6.0	6,000.00	36,000
309	Structural steel support, overhead batting cage	EA	1.0	6,000.00	6,000
118	Elevator hoist beam	EA	1.0	10,000.00	10,000

BCYF COMMUNITY CENTER - CHARLESTOWN

CONCEPT DESIGN COST ESTIMATE - REVISION 1



LOCATION DIVISIONS/ELEMENTS ITEM

B Building & Sitework (continued)

GFA: 23,936 SF Cost/SF: 890.95
Rates Current At February 2023

Ref	Description	Unit	Qty	Rate \$	Total Cost \$
119	Elevator pit ladder	EA	1.0	1,500.00	1,500
120	Elevator sump pit grate and frame	EA	1.0	1,200.00	1,200
121	Miscellaneous metals (MEP supports, casework supports, operable wall support, etc)	SF	23,936.0	5.00	119,680
	C1030 - Fittings			14.08/SF	337,030
C2010	Stair Construction				
209	48" Wide metal pan stair w/- concrete filled treads and landings (egress stair)	FT/R	27.0	2,250.00	60,750
210	48" Wide decorative circulation stair (Entry)	FT/R	30.0	10,000.00	300,000
	C2010 - Stair Construction			15.07/SF	360,750
	05 - METALS			141.22/SF	3,380,310
06	WOOD, PLASTICS, AND COMPOSITES				
C1030	Fittings				
122	Wood blocking / rough carpentry	SF	23,936.0	2.00	47,872
	C1030 - Fittings			2.00/SF	47,872
E2010	Fixed Furnishings				
189	Built-in casework to Art Room (base cabinet and overheads, closet shelving)	SF	1,215.0	8.00	9,720
190	Built-in casework to Circulation (none)	SF	2,917.0		Excl.
191	Built-in casework to Community Room (kitchenette, storage shelving)	SF	1,668.0	10.00	16,680
192	Built-in casework to Entry (reception desk, built-in benches, shelving, displays, etc)	SF	678.0	50.00	33,900
193	Built-in casework to Fitness Room (cubbies, misc. storage)	SF	1,211.0	8.00	9,688
194	Built-in casework to Gymnasium (nutrition station, misc. storage built-ins, etc)	SF	3,463.0	2.50	8,658
195	Built-in casework to Kitchen (base cabinet and overhead, cooking island)	SF	607.0	60.00	36,420
376	Built-in casework to Lobby (built-in benches, shelving, displays, etc)	SF	1,445.0	30.00	43,350
196	Built-in casework to Locker (vanity, changing bench, towel-drop, shower shelf, etc)	SF	1,011.0	25.00	25,275
197	Built-in casework to Makerspace (workstations, printer stations, base cabinets, peg boards)	SF	1,660.0	20.00	33,200
199	Built-in casework to Office (none)	SF	636.0		Excl.

BCYF COMMUNITY CENTER - CHARLESTOWN

CONCEPT DESIGN COST ESTIMATE - REVISION 1



LOCATION DIVISIONS/ELEMENTS ITEM

B Building & Sitework (continued)

GFA: 23,936 SF Cost/SF: 890.95
Rates Current At February 2023

Ref	Description	Unit	Qty	Rate \$	Total Cost \$
201	Built-in casework to Senior Room (closet shelving, kitchenette)	SF	773.0	12.00	9,276
203	Built-in casework to Tech Room (cubbies, wall units)	SF	665.0	12.00	7,980
375	Built-in casework to Teen Center (closet shelving, base cabinets, cubbies, etc)	SF	1,639.0	20.00	32,780
205	Built-in casework to Youth Classroom (closet shelving, base cabinets, cubbies, etc)	SF	1,184.0	20.00	23,680
206	Built-in casework to Youth Flex Space (base cabinets, cubbies, kitchenette, vanity)	SF	1,150.0	25.00	28,750
	E2010 - Fixed Furnishings			13.34/SF	319,357
	06 - WOOD, PLASTICS, AND COMPOSITES			15.34/SF	367,229
07	THERMAL AND MOISTURE PROTECTION				
A1030	Slab on Grade				
73	Vapor barrier to slab on grade	SF	1,811.0	0.90	1,630
74	Rigid insulation to slab on grade	SF	1,811.0	5.50	9,961
211	Underslab waterproofing	SF	1,811.0		Excl.
	A1030 - Slab on Grade			0.48/SF	11,591
A2020	Basement Walls				
75	Rigid insulation to foundation wall	SF	1,529.0	5.50	8,410
	A2020 - Basement Walls			0.35/SF	8,410
B1010	Floor Construction				
362	Insulation at floor construction above open parking	SF	12,641.0	12.00	151,692
90	Spray-applied fireproofing to structural steel floor framing	SF	21,534.0	5.00	107,670
	B1010 - Floor Construction			10.84/SF	259,362
B1020	Roof Construction				
91	Spray-applied fireproofing to structural steel roof framing	SF	14,090.0	5.00	70,450
	B1020 - Roof Construction			2.94/SF	70,450
B2010	Exterior Walls				
92	Exterior metal wall panel, impact-resistant	SF	13,926.0	110.00	1,531,860
106	Exterior metal soffit panel (exterior parking)	SF	12,641.0	125.00	1,580,125
94	Air and vapor barrier	SF	13,926.0	7.50	104,445
95	Rigid insulation	SF	13,926.0	5.50	76,593
96	Batt insulation	SF	13,926.0	3.00	41,778
212	Exterior caulking and sealing	SF	13,926.0	2.00	27,852

BCYF COMMUNITY CENTER - CHARLESTOWN

CONCEPT DESIGN COST ESTIMATE - REVISION 1



LOCATION DIVISIONS/ELEMENTS ITEM

B Building & Sitework (continued)

GFA: 23,936 SF Cost/SF: 890.95
Rates Current At February 2023

Ref	Description	Unit	Qty	Rate \$	Total Cost \$
98	Miscellaneous trims and flashings	SF	13,926.0	2.00	27,852
371	Misc. demolition and repairs at exst. exterior envelope	EA	2.0	100,000.00	200,000
	B2010 - Exterior Walls			150.00/SF	3,590,505
B3010	Roof Coverings				
104	Membrane roofing incl. back-up assembly (insulation, coverboard, etc)	SF	14,090.0	35.00	493,150
363	Premium for green roof	SF	999.0	75.00	74,925
227	Finish at inside face of parapet	SF	1,636.0	30.00	49,080
226	Parapet cap	LF	655.0	60.00	39,300
105	Roof walkway pads	SF	705.0	15.00	10,575
213	Roof safety fall-arrest system	LS	1.0	25,000.00	25,000
	B3010 - Roof Coverings			28.91/SF	692,030
C1030	Fittings				
123	Firestopping	SF	23,936.0	1.00	23,936
124	Interior caulking and sealing	SF	23,936.0	1.50	35,904
	C1030 - Fittings			2.50/SF	59,840
	07 - THERMAL AND MOISTURE PROTECTION			196.03/SF	4,692,188
08	OPENINGS				
B2010	Exterior Walls				
93	Exterior curtain wall system, triple-glazed, impact-resistant	SF	7,499.0	200.00	1,499,800
	B2010 - Exterior Walls			62.66/SF	1,499,800
B2030	Exterior Doors				
99	Double-leaf glass door, including frame, finish, and hardware	Pair	1.0	14,000.00	14,000
100	Single-leaf glass door, including frame, finish, and hardware	EA	1.0	7,000.00	7,000
101	Double-leaf wood/metal door, including frame, finish, and hardware (none indicated)	Pair	1.0		Excl.
102	Single-leaf wood/metal door, including frame, finish, and hardware	EA	1.0	3,000.00	3,000
103	Automatic door operator	EA	1.0	4,500.00	4,500
	B2030 - Exterior Doors			1.19/SF	28,500
C1010	Partitions				
107	Interior storefront, punched windows, etc (GFA measured)	SF	23,936.0	4.00	95,744
	C1010 - Partitions			4.00/SF	95,744

BCYF COMMUNITY CENTER - CHARLESTOWN

CONCEPT DESIGN COST ESTIMATE - REVISION 1



LOCATION DIVISIONS/ELEMENTS ITEM

B Building & Sitework (continued)

GFA: 23,936 SF Cost/SF: 890.95
Rates Current At February 2023

Ref	Description	Unit	Qty	Rate \$	Total Cost \$
C1020	Interior Doors				
113	Interior doors, frames, and hardware (GFA measured)	SF	23,936.0	4.50	107,712
379	Interior doors, frames, and hardware (connections to exst. building)	EA	2.0	30,000.00	60,000
	C1020 - Interior Doors			7.01/SF	167,712
C1030	Fittings				
374	Exterior glass guardrail	LF	54.0	750.00	40,500
	C1030 - Fittings			1.69/SF	40,500
	08 - OPENINGS			76.55/SF	1,832,256
09	FINISHINGS				
B2010	Exterior Walls				
97	Back-up wall assembly to metal panel (CFMF, sheathing, GWB)	SF	13,926.0	26.00	362,076
	B2010 - Exterior Walls			15.13/SF	362,076
C1010	Partitions				
108	Drywall partition, standard	SF	4,767.0	20.00	95,340
109	Drywall partition, acoustic	SF	7,060.0	25.00	176,500
111	Drywall partition, furred CMU	SF	4,027.0	12.00	48,324
110	Drywall partitions not yet identified (GFA measured)	SF	23,936.0	7.50	179,520
	C1010 - Partitions			20.88/SF	499,684
C2020	Stair Finishes				
132	Resilient flooring to egress stairs	SF	453.0	20.00	9,060
133	Decorative flooring to circulation stairs	SF	117.0		Incl.
134	Resilient wall base to egress stairs	LF	167.0	5.00	835
135	Decorative wall base to circulation stairs	SF	46.0		Incl.
	C2020 - Stair Finishes			0.41/SF	9,895
C3010	Wall Finishes				
174	Wall finish to Entry (assumes wood wall panel, 80% of wall area)	SF	1,364.0	65.00	88,660
175	Wall finish to Youth Flex Space (assumes wallcovering, 50% of wall area)	SF	710.0	20.00	14,200
176	Wall finish to Community Room (assumes wood wall panel, 50% of wall area)	SF	830.0	65.00	53,950
177	Wall finish to Kitchen (assumes tiled backsplash)	SF	170.0	35.00	5,950

BCYF COMMUNITY CENTER - CHARLESTOWN

CONCEPT DESIGN COST ESTIMATE - REVISION 1



LOCATION DIVISIONS/ELEMENTS ITEM

B Building & Sitework (continued)

GFA: 23,936 SF Cost/SF: 890.95
Rates Current At February 2023

Ref	Description	Unit	Qty	Rate \$	Total Cost \$
178	Wall finish to Gymnasium (assumes safety wall pads, 96" high)	SF	1,895.0	16.00	30,320
179	Wall finish to Gymnasium (assumes acoustic wall panel, 20% of wall area)	SF	1,137.0	28.00	31,836
180	Wall finish to Locker Rooms (assumes ceramic wall tile, full height)	SF	5,586.0	24.00	134,064
182	Wall finishes not yet identified (GFA measured)	SF	23,936.0	2.00	47,872
	C3010 - Wall Finishes			17.00/SF	406,852
C3020	Floor Finishes				
136	Floor finish to Art Room (assumes heavy duty resilient flooring)	SF	1,215.0	16.00	19,440
137	Floor finish to Circulation (assumes heavy duty resilient flooring)	SF	2,917.0	16.00	46,672
138	Floor finish to Community Room (assumes premium resilient flooring)	SF	1,668.0	18.00	30,024
139	Floor finish to Entry (assumes heavy duty resilient flooring)	SF	678.0	16.00	10,848
140	Floor finish to Fitness Room (assumes sports flooring)	SF	1,211.0	24.00	29,064
141	Floor finish to Gymnasium (assumes sports flooring)	SF	3,463.0	24.00	83,112
142	Floor finish to Kitchen (assumes epoxy flooring)	SF	607.0	18.00	10,926
367	Floor finish to Lobby (assumes heavy duty resilient flooring)	SF	1,445.0	16.00	23,120
143	Floor finish to Locker (assumes ceramic tile)	SF	1,011.0	26.00	26,286
144	Floor finish to Makerspace (assumes heavy duty resilient flooring)	SF	1,660.0	16.00	26,560
146	Floor finish to Office (assumes heavy duty resilient flooring)	SF	636.0	16.00	10,176
148	Floor finish to Senior Center (assumes heavy duty resilient flooring)	SF	773.0	16.00	12,368
150	Floor finish to Tech Room (assumes heavy duty resilient flooring)	SF	665.0	16.00	10,640
368	Floor finish to Teen Center (assumes heavy duty resilient flooring)	SF	1,639.0	16.00	26,224
152	Floor finish to Youth Classroom (assumes heavy duty resilient flooring)	SF	1,184.0	16.00	18,944
153	Floor finish to Youth Flex Space (assumes heavy duty resilient flooring)	SF	1,150.0	16.00	18,400
172	Wall bases (GFA measured)	SF	23,936.0	2.00	47,872
173	Moisture mitigation	SF	15,624.0	5.50	85,932
	C3020 - Floor Finishes			22.42/SF	536,608

BCYF COMMUNITY CENTER - CHARLESTOWN

CONCEPT DESIGN COST ESTIMATE - REVISION 1



LOCATION DIVISIONS/ELEMENTS ITEM

B Building & Sitework (continued)

GFA: 23,936 SF Cost/SF: 890.95
Rates Current At February 2023

Ref	Description	Unit	Qty	Rate \$	Total Cost \$
C3030	Ceiling Finishes				
154	Ceiling finish to Art Room (assumes ACT)	SF	1,215.0	12.00	14,580
155	Ceiling finish to Circulation (assumes ACT)	SF	2,917.0	12.00	35,004
156	Ceiling finish to Community Room (assumes 50% decorative ACT/ 50% painted GWB)	SF	1,668.0	35.00	58,380
157	Ceiling finish to Entry (assumes assumes premium ACT / clouds)	SF	678.0	45.00	30,510
158	Ceiling finish to Fitness Room (assumes ACT)	SF	1,211.0	15.00	18,165
159	Ceiling finish to Gymnasium (assumes painted exposed structure)	SF	3,463.0	3.50	12,121
160	Ceiling finish to Kitchen (assumes vinyl-faced ACT)	SF	607.0	16.00	9,712
370	Ceiling finish to Lobby (assumes assumes premium ACT / clouds)	SF	1,445.0	45.00	65,025
161	Ceiling finish to Locker (assumes painted GWB)	SF	1,011.0	30.00	30,330
162	Ceiling finish to Makerspace (assumes ACT)	SF	1,660.0	12.00	19,920
164	Ceiling finish to Office (assumes ACT)	SF	636.0	12.00	7,632
166	Ceiling finish to Senior Center (assumes premium ACT)	SF	773.0	15.00	11,595
168	Ceiling finish to Tech Room (assumes ACT)	SF	665.0	12.00	7,980
369	Ceiling finish to Teen Center (assumes ACT)	SF	1,639.0	12.00	19,668
170	Ceiling finish to Youth Classroom (assumes ACT)	SF	1,184.0	12.00	14,208
171	Ceiling finish to Youth Flex Space (assumes ACT / clouds)	SF	1,150.0	45.00	51,750
	C3030 - Ceiling Finishes			16.99/SF	406,580
	09 - FINISHINGS			92.82/SF	2,221,695
10	SPECIALTIES				
C1010	Partitions				
112	Operable partition, manually operated (Community Room, Fitness)	SF	706.0	100.00	70,600
	C1010 - Partitions			2.95/SF	70,600
C1030	Fittings				
125	Allowance for metal lockers	SF	23,936.0	1.00	23,936
126	Restroom accessories including compartments, grab bars, toilet paper holders, shower curtain, etc.	SF	23,936.0	1.75	41,888
127	Janitor accessories	LS	1.0	1,000.00	1,000
128	Fire extinguisher and cabinet	EA	10.0	450.00	4,500
129	Corner guards and crash rails	SF	23,936.0	0.50	11,968

BCYF COMMUNITY CENTER - CHARLESTOWN

CONCEPT DESIGN COST ESTIMATE - REVISION 1



LOCATION DIVISIONS/ELEMENTS ITEM

B Building & Sitework (continued)

GFA: 23,936 SF Cost/SF: 890.95
Rates Current At February 2023

Ref	Description	Unit	Qty	Rate \$	Total Cost \$
242	Markerboards / tackboards	SF	23,936.0	0.75	17,952
130	Interior code and wayfinding signage	SF	23,936.0	1.25	29,920
131	Exterior building signage	LS	1.0	20,000.00	20,000
	C1030 - Fittings			6.32/SF	151,164
	10 - SPECIALTIES			9.26/SF	221,764
11	EQUIPMENT				
E1010	Commercial Equipment				
184	Residential appliance package, kitchenette (undercounter refrigerator, dishwasher, microwave)	EA	3.0	3,500.00	10,500
305	Residential appliance package w/- commercial hood, Community Kitchen (cooktop, oven, dishwasher, microwave, refrigerator)	EA	1.0	30,000.00	30,000
304	Laundry equipment (residential-grade)	LS	1.0	7,500.00	7,500
	E1010 - Commercial Equipment			2.01/SF	48,000
E1020	Institutional Equipment				
185	Projection screen	EA	6.0	3,500.00	21,000
186	Projector (assumes FF&E by Owner)	EA	6.0		Excl.
187	Televisions (assumes FF&E by Owner)	EA	12.0		Excl.
316	3D Printers, laser cutters, fume hoods, etc (assumes by Owner)	LS	1.0		Excl.
	E1020 - Institutional Equipment			0.88/SF	21,000
E1090	Other Equipment				
243	Backstop (retractable, ceiling-mounted)	EA	2.0	10,000.00	20,000
306	Batting cage (retractable, ceiling mounted)	EA	1.0	15,000.00	15,000
307	Volleyball court inserts, sleeves, etc	EA	1.0	5,000.00	5,000
244	Scoreboard	EA	1.0	20,000.00	20,000
246	Shot clock	EA	1.0	5,000.00	5,000
245	Gymnasium divider netting	SF	1,318.0	20.00	26,360
	E1090 - Other Equipment			3.82/SF	91,360
	11 - EQUIPMENT			6.70/SF	160,360
12	FURNISHINGS				
E2010	Fixed Furnishings				
188	Window shades to exterior glazing (assumes 70% manually operated)	SF	5,249.0	18.00	94,482

BCYF COMMUNITY CENTER - CHARLESTOWN

CONCEPT DESIGN COST ESTIMATE - REVISION 1



LOCATION DIVISIONS/ELEMENTS ITEM

B Building & Sitework (continued)

GFA: 23,936 SF Cost/SF: 890.95
Rates Current At February 2023

Ref	Description	Unit	Qty	Rate \$	Total Cost \$
364	Window shades to exterior glazing (assumes 30% motorized operated)	SF	2,250.0	25.00	56,250
	E2010 - Fixed Furnishings			6.30/SF	150,732
E2020	Movable Furnishings				
220	Loose furniture, fittings, and equipment - FF&E (by Owner)	LS	1.0		Excl.
	E2020 - Movable Furnishings				Excl.
	12 - FURNISHINGS			6.30/SF	150,732
14	CONVEYING EQUIPMENT				
D1010	Elevators & Lifts				
221	(3) Stop passenger elevator	EA	2.0	210,000.00	420,000
222	Upgraded cab finishes	EA	2.0	25,000.00	50,000
	D1010 - Elevators & Lifts			19.64/SF	470,000
	14 - CONVEYING EQUIPMENT			19.64/SF	470,000
21	FIRE SUPPRESSION				
D4010	Sprinklers				
335	Wet sprinkler system c/w zone control, schedule 40 steel distribution, sprinkler heads, testing etc.	SF	23,936.0	8.00	191,488
	D4010 - Sprinklers			8.00/SF	191,488
D4090	Other Fire Protection Systems				
340	General Requirements: supervision, shop drawings, as-built drawings, tags, markers, tools, rentals, permits, fees etc.	Item			19,000
	D4090 - Other Fire Protection Systems			0.79/SF	19,000
	21 - FIRE SUPPRESSION			8.79/SF	210,488
22	PLUMBING				
D2010	Plumbing Fixtures				
346	Plumbing fixtures c/w hook up	SF	23,936.0	3.50	83,776
	D2010 - Plumbing Fixtures			3.50/SF	83,776
D2020	Domestic Water Distribution				
347	Water heating plant c/w equipment, insulated distribution etc.	SF	23,936.0	3.00	71,808
348	Insulated distribution c/w fittings, hangers etc.	SF	23,936.0	4.00	95,744
349	Equipment and plumbing fixture hook-up connections	SF	23,936.0	1.25	29,920

BCYF COMMUNITY CENTER - CHARLESTOWN

CONCEPT DESIGN COST ESTIMATE - REVISION 1



LOCATION DIVISIONS/ELEMENTS ITEM

B Building & Sitework (continued)

GFA: 23,936 SF Cost/SF: 890.95
Rates Current At February 2023

Ref	Description	Unit	Qty	Rate \$	Total Cost \$
350	Miscellaneous items: trap seal primers system, water hammer arrestors, valves, access doors etc.	SF	23,936.0	0.75	17,952
	D2020 - Domestic Water Distribution			9.00/SF	215,424
D2030	Sanitary Waste				
355	Sanitary drainage system c/w floor drains, clean outs, distribution grease interceptor, excavation bedding and backfill etc.	SF	23,936.0	6.50	155,584
356	Plumbing fixture hookup connections	SF	23,936.0	1.00	23,936
357	Venting	SF	23,936.0	2.50	59,840
	D2030 - Sanitary Waste			10.00/SF	239,360
D2040	Rain Water Drainage				
352	Storm drainage system c/w roof drains, clean outs, distribution, excavation bedding and backfill etc.	SF	23,936.0	2.50	59,840
	D2040 - Rain Water Drainage			2.50/SF	59,840
D2090	Other Plumbing Systems				
351	General Requirements: supervision, shop drawings, as-build drawings, tags, markers, tools, rentals, permits, fees etc.	Item			61,000
354	Kitchen equipment indirect drain and water hook-up connections	SF	607.0	20.00	12,140
	D2090 - Other Plumbing Systems			3.06/SF	73,140
	22 - PLUMBING			28.06/SF	671,540
23	HEATING, VENTILATING, AND AIR CONDITIONING				
D3010	Energy Supply				
1	80 tons Hyper Heat VRF system c/w ducted fan coils , condensing units and BC controllers	EA	80.0	6,000.00	480,000
320	10 tons Hyper Heat VRF system c/w ducted fan coils , condensing units and BC controllers	EA	10.0	6,000.00	60,000
319	Insulated refrigerant piping c/w equipment hook-ups	SF	16,756.0	6.25	104,725
328	Refrigerant charge Lbs.	Lb	650.0	25.00	16,250
	D3010 - Energy Supply			27.61/SF	660,975
D3040	Distribution Systems				
6	Rectangular galvanized ductwork c/w fittings, hangers, etc.	Lb	20,346.0	14.00	284,844
7	Thermal insulation	SF	23,936.0	3.00	71,808
329	Diffusers and grilles	SF	23,936.0	1.75	41,888

BCYF COMMUNITY CENTER - CHARLESTOWN

CONCEPT DESIGN COST ESTIMATE - REVISION 1



LOCATION DIVISIONS/ELEMENTS ITEM

B Building & Sitework (continued)

GFA: 23,936 SF Cost/SF: 890.95
Rates Current At February 2023

Ref	Description	Unit	Qty	Rate \$	Total Cost \$
330	Fire dampers, louvers, motorized dampers etc	SF	23,936.0	1.00	23,936
	D3040 - Distribution Systems			17.65/SF	422,476
D3050	Terminal & Package Units				
5	5,000 cfm ERV- serving the locker rooms	LS	1.0	95,000.00	95,000
9	5,000 cfm heat-pump air handler serving the gym	EA	6.0	60,000.00	360,000
318	4000 cfm MUA serving the kitchen	EA	1.0	30,000.00	30,000
323	4000 cfm exhaust serving the kitchen	LS	1.0	3,000.00	3,000
321	Kitchen 8 foot hood c/w fire suppression system	LS	1.0	10,000.00	10,000
322	Nederman exhaust arms - 650 cfm	No	6.0	3,500.00	21,000
325	4000 cfm exhaust serving the maker space	LS	1.0	30,000.00	30,000
327	Miscellaneous fan coils, FFH, UH's, etc	SF	23,936.0	1.00	23,936
	D3050 - Terminal & Package Units			23.94/SF	572,936
D3060	Controls & Instrumentations				
331	BAS Controls c/w front end work station, graphics, wiring, devices, testing etc.	SF	23,936.0	8.00	191,488
	D3060 - Controls & Instrumentations			8.00/SF	191,488
D3070	Systems Testing & Balancing				
332	Air Balancing c/w report	SF	23,936.0	0.50	11,968
333	Third party commissioning c/w report	SF	23,936.0	1.50	35,904
	D3070 - Systems Testing & Balancing			2.00/SF	47,872
D3090	Other HVAC Systems & Equipment				
334	General Requirements: supervision, shop drawings, as-build drawings, tags, markers, tools, rentals, permits, fees etc.	Item			190,000
	D3090 - Other HVAC Systems & Equipment			7.94/SF	190,000
	23 - HEATING, VENTILATING, AND AIR CONDITIONING			87.14/SF	2,085,747
26	ELECTRICAL				
D5010	Electrical Service & Distribution				
23	Main switch board, transformers, branch power and lighting panels, feeders	SF	23,936.0	12.00	287,232
21	Emergency generator (including panels, ATS, controls)	EA	1.0	125,000.00	125,000
20	Utility transformer backcharge allowance	EA	1.0	50,000.00	50,000
	D5010 - Electrical Service & Distribution			19.31/SF	462,232
D5020	Lighting and Branch Wiring				
24	Mechanical equipment connections	SF	23,936.0	2.50	59,840

BCYF COMMUNITY CENTER - CHARLESTOWN

CONCEPT DESIGN COST ESTIMATE - REVISION 1



LOCATION DIVISIONS/ELEMENTS ITEM
B Building & Sitework (continued)

GFA: 23,936 SF Cost/SF: 890.95
Rates Current At February 2023

Ref	Description	Unit	Qty	Rate \$	Total Cost \$
26	Entry-Lighting and branch power	SF	678.0	15.00	10,170
372	Lobby-Lighting and branch power	SF	1,445.0	15.00	21,675
28	Circulation-Lighting and branch power	SF	2,917.0	10.00	29,170
29	Community-Lighting and branch power	SF	1,668.0	12.00	20,016
31	Gym area (double court, fitness, lockers)-Lighting and branch power	SF	3,463.0	25.00	86,575
43	Kitchen area-Lighting and branch power	SF	607.0	25.00	15,175
44	Office area-Lighting and branch power	SF	636.0	12.00	7,632
46	Stairwell area-Lighting and branch power	SF	453.0	10.00	4,530
48	Senior center-Lighting and branch power	SF	773.0	15.00	11,595
51	Fitness area-Lighting and branch power	SF	1,211.0	18.00	21,798
52	Locker area-Lighting and branch power	SF	1,011.0	18.00	18,198
54	Youth classroom-Lighting and branch power	SF	1,184.0	15.00	17,760
55	Youth Flex area-Lighting and branch power	SF	1,150.0	15.00	17,250
373	Teen center-Lighting and branch power	SF	1,639.0	15.00	24,585
56	Art room area-Lighting and branch power	SF	1,215.0	15.00	18,225
57	Makerspace area-Lighting and branch power	SF	1,660.0	15.00	24,900
58	Tech lab area-Lighting and branch power	SF	665.0	25.00	16,625
	D5020 - Lighting and Branch Wiring			17.79/SF	425,719
D5090	Other Electrical Systems				
13	Grounding	SF	23,936.0	0.75	17,952
15	AV/Sound system infrastructure only-equipment by others	SF	23,936.0	1.25	29,920
16	PV solar system (conduit and misc. infrastructure only)	LS	1.0	20,000.00	20,000
17	BDA antenna system	LS	1.0	20,000.00	20,000
18	Lightning protection	SF	23,936.0	0.75	17,952
	D5090 - Other Electrical Systems			4.42/SF	105,824
G4010	Electrical Distribution				
41	Primary feeder ductbank underground empty-concrete encased allowance	LF	500.0	175.00	87,500
42	2000A Secondary feeder ductbank encased in concrete-allowance	LF	100.0	750.00	75,000
	G4010 - Electrical Distribution			6.79/SF	162,500
G4020	Site Lighting				
382	Terrace-Lighting and branch power	SF	999.0	10.00	9,990

BCYF COMMUNITY CENTER - CHARLESTOWN

CONCEPT DESIGN COST ESTIMATE - REVISION 1



LOCATION DIVISIONS/ELEMENTS ITEM
B Building & Sitework (continued)

GFA: 23,936 SF Cost/SF: 890.95
Rates Current At February 2023

Ref	Description	Unit	Qty	Rate \$	Total Cost \$
47	Exterior parking area-Lighting and branch power-(1) EV station	SF	12,402.0	5.00	62,010
	G4020 - Site Lighting			3.01/SF	72,000
	26 - ELECTRICAL			51.31/SF	1,228,275
27	COMMUNICATIONS				
D5030	Communications & Security				
14	TELECOM infrastructure system including racks, CAT 6 & fiber	SF	23,936.0	6.00	143,616
	D5030 - Communications & Security			6.00/SF	143,616
	27 - COMMUNICATIONS			6.00/SF	143,616
28	ELECTRONIC SAFETY AND SECURITY				
D5030	Communications & Security				
10	Fire Alarm system	SF	23,936.0	5.50	131,648
12	Security system infrastructure including equipment	SF	23,936.0	2.00	47,872
	D5030 - Communications & Security			7.50/SF	179,520
	28 - ELECTRONIC SAFETY AND SECURITY			7.50/SF	179,520
31	EARTHWORK				
A1010	Standard Foundations				
64	Excavation for concrete foundations	CY	458.0	20.00	9,160
65	Remove and dispose of excavated spoils	CY	458.0	30.00	13,740
66	Imported backfill to foundation excavation	CY	106.0	55.00	5,830
71	Sub-soil perimeter drain	LF	437.0	25.00	10,925
	A1010 - Standard Foundations			1.66/SF	39,655
A1030	Slab on Grade				
67	Excavation for new slab on grade	CY	79.0	20.00	1,580
68	Remove and dispose of excavated spoils	CY	79.0	30.00	2,370
69	Imported granular subbase to slab on grade	CY	45.0	55.00	2,475
70	Trim and compact subgrade	SF	1,811.0	1.00	1,811
	A1030 - Slab on Grade			0.34/SF	8,236
G1010	Site Clearing				
247	Site clearing and grubbing	LS	1.0	10,000.00	10,000
291	Temporary site fencing	LF	601.0	25.00	15,025
292	Construction entrance, wash-down, etc	LS	1.0	10,000.00	10,000

BCYF COMMUNITY CENTER - CHARLESTOWN

CONCEPT DESIGN COST ESTIMATE - REVISION 1



LOCATION DIVISIONS/ELEMENTS ITEM
B Building & Sitework (continued)

GFA: 23,936 SF Cost/SF: 890.95
Rates Current At February 2023

Ref	Description	Unit	Qty	Rate \$	Total Cost \$
293	Temporary erosion and sediment control, dust control, etc	LS	1.0	50,000.00	50,000
	G1010 - Site Clearing			3.55/SF	85,025
G1020	Site Demolition and Relocations				
248	Sawcut, break-up, and remove existing asphalt parking lot	SF	16,606.0	2.00	33,212
249	Sawcut, break-up, and remove existing concrete pavement	SF	3,310.0	2.00	6,620
380	Remove and dispose existing road curb	LF	785.0	15.00	11,775
384	Remove and dispose existing trees	EA	13.0	400.00	5,200
385	Remove and dispose existing light poles	EA	2.0	1,500.00	3,000
386	Remove and dispose existing traffic sign poles	EA	3.0	400.00	1,200
250	Miscellaneous site demolition not yet identified	LS	1.0	20,000.00	20,000
	G1020 - Site Demolition and Relocations			3.38/SF	81,007
G1030	Site Earthwork				
252	Site grading, cut and fill	SF	27,347.0	2.00	54,694
253	Excavation in rock (assumes not required)	LS	1.0		Excl.
254	Excavation in contaminated soils (assumes not required)	LS	1.0		Excl.
255	Dewatering (assumes not required)	LS	1.0		Excl.
	G1030 - Site Earthwork			2.29/SF	54,694
G1040	Hazardous Waste Remediation				
251	Hazardous materials abatement (assumes not required)	LS	1.0		Excl.
	G1040 - Hazardous Waste Remediation				Excl.
	31 - EARTHWORK			11.22/SF	268,617
32	EXTERIOR IMPROVEMENTS				
G2020	Parking Lots				
259	Asphalt parking lot (incl. excavation, subgrade, etc)	SY	2,258.0	65.00	146,770
260	Curb	LF	590.0	60.00	35,400
261	Linemarking	SF	20,319.0	0.25	5,080
262	Traffic signage	LS	1.0	5,000.00	5,000
266	Reinstate existing drive entrance	EA	1.0	10,000.00	10,000
	G2020 - Parking Lots			8.45/SF	202,250
G2030	Pedestrian Paving				
263	Decorative unit paver (Entry Court)	SF	1,200.0	35.00	42,000
383	Miscellaneous walkway modification	LS	1.0	25,000.00	25,000
	G2030 - Pedestrian Paving			2.80/SF	67,000

BCYF COMMUNITY CENTER - CHARLESTOWN

CONCEPT DESIGN COST ESTIMATE - REVISION 1



LOCATION DIVISIONS/ELEMENTS ITEM
B Building & Sitework (continued)

GFA: 23,936 SF Cost/SF: 890.95
Rates Current At February 2023

Ref	Description	Unit	Qty	Rate \$	Total Cost \$
G2040	Site Development				
271	Miscellaneous site development not yet identified	LS	1.0	100,000.00	100,000
	G2040 - Site Development			4.18/SF	100,000
G2050	Landscaping				
381	Plantings at Green roof	LS	1.0	5,000.00	5,000
273	Reinstate surrounding landscaping	LS	1.0	20,000.00	20,000
	G2050 - Landscaping			1.04/SF	25,000
	32 - EXTERIOR IMPROVEMENTS			16.47/SF	394,250
33	UTILITIES				
G3010	Water Supply				
341	Water services c/w street connection, distribution, valves, excavation, bedding and backfill, thrust blocks etc.	LS	1.0	50,000.00	50,000
343	Fire Water services c/w street connection, distribution, valves, excavation, bedding and backfill, thrust blocks etc.	LS	1.0	50,000.00	50,000
	G3010 - Water Supply			4.18/SF	100,000
G3020	Sanitary Water				
342	Sanitary drainage services c/w street connection, distribution, manholes, excavation, bedding and backfill etc.	LS	1.0	75,000.00	75,000
	G3020 - Sanitary Water			3.13/SF	75,000
G3030	Storm Sewer				
344	Storm water drainage system c/w manholes, catch basins, distribution, excavation bedding and backfill etc.	LS	1.0	150,000.00	150,000
345	Storm water retention system	LS	1.0	300,000.00	300,000
	G3030 - Storm Sewer			18.80/SF	450,000
	33 - UTILITIES			26.11/SF	625,000
	BUILDING & SITEWORK			890.95/SF	21,325,870

A.4 Reference : Devine Rink Test-fit Cost Estimates

For reference, a stand alone facility on the Navy Yard/ Spaulding site and Charlestown High School site would be comparable to the stand alone facility at the Devine Rink site studied in the BCYF Dorchester Programming & Siting study. A soft cost estimate for furniture, fixtures, and equipment was generated based on this comparable facility. The cost numbers are escalated to reflect a Q3 2027 construction start with a 24 month construction duration

This section includes concept design costs for the Devine Rink site option, representing the likely construction costs among the options studied. .

COST ESTIMATE SUMMARY	
HARD COST ESTIMATE*	
DEVINE RINK SITE	\$51,154,540
SOFT COST FF&E ESTIMATE	
Community rooms, senior/teen/youth rooms, lobby, offices, fitness rooms	\$325,000
Makerspace equipment	\$150,000
AV equipment	\$360,000
Pool	\$25,000
IT and computer equipment	\$1,200,000
SOFT COST TOTAL	\$2,060,000
TOTAL COST RANGE (Hard costs and FF&E costs)	\$53,214,540

*see following pages for a full breakdown of the hard cost estimate

page not used

BCYF DORCHESTER
CONCEPT DESIGN COST ESTIMATE - REVISION 2



LOCATION SUMMARY

GFA: Gross Floor Area
 Rates Current At April 2022

CHARLESTOWN HIGH SCHOOL SITE - SHARED FACILITY OPTION			
	GFA SF	GFA \$/SF	Total Cost \$
DR Devine Rink Site	53,000	643.10	34,084,043
ESTIMATED NET COST	53,000	643.10	34,084,043
MARGINS & ADJUSTMENTS			
General Conditions / Requirements	9.5 %		3,237,985
Bonds and Insurances	2.8 %		1,026,356
Overhead and Profit	4.5 %		1,725,678
Construction Contingency			Excl.
Design / Estimating Contingency	15.0 %		6,011,109
Subtotal (excl. Escalation)	53,000	869.53	46,085,171
Escalation to Q4 2024	11.0 %		5,069,369
ESTIMATED TOTAL COST	53,000	965.18	51,154,540

BCYF DORCHESTER
CONCEPT DESIGN COST ESTIMATE - REVISION 2



LOCATION DIVISIONS/ELEMENTS SUMMARY

GFA: 53,000 SF Cost/SF: 643.10
 Rates Current At April 2022

Ref	Description	%	GFA \$/SF	Total Cost \$
03	Concrete			
A1010	Standard Foundations		1.66	88,060
A1020	Special Foundations			Excl.
A1030	Slab on Grade		1.09	57,856
A2020	Basement Walls		1.95	103,415
B1010	Floor Construction		51.06	2,706,193
B1020	Roof Construction		4.31	228,353
C1010	Partitions		10.11	535,590
C1030	Fittings		0.09	5,000
	03 - Concrete		70.27	3,724,467
05	Metals			
B1010	Floor Construction		43.73	2,317,623
B1020	Roof Construction		30.96	1,641,003
C1030	Fittings		7.20	381,362
C2010	Stair Construction		3.79	201,000
	05 - Metals		85.68	4,540,988
06	Wood, Plastics, and Composites			
C1030	Fittings		2.00	106,000
E2010	Fixed Furnishings		5.73	303,636
	06 - Wood, Plastics, and Composites		7.73	409,636
07	Thermal and Moisture Protection			
A1030	Slab on Grade		0.51	26,824
A2020	Basement Walls		0.08	4,036
B1010	Floor Construction		7.80	413,509
B1020	Roof Construction		1.76	93,417
B2010	Exterior Walls		83.86	4,444,400
B3010	Roof Coverings		17.86	946,599
C1030	Fittings		2.50	132,500
	07 - Thermal and Moisture Protection		114.36	6,061,285
08	Openings			
B2010	Exterior Walls		37.74	2,000,000
B2030	Exterior Doors		1.01	53,500
C1010	Partitions		3.00	159,000
C1020	Interior Doors		3.50	185,500
	08 - Openings		45.25	2,398,000

BCYF DORCHESTER
CONCEPT DESIGN COST ESTIMATE - REVISION 2



LOCATION DIVISIONS/ELEMENTS SUMMARY

DR Devine Rink Site (continued)

GFA: 53,000 SF Cost/SF: 643.10
 Rates Current At April 2022

Ref	Description	%	GFA \$/SF	Total Cost \$
09	Finishings			
B2010	Exterior Walls		10.75	570,000
C1010	Partitions		15.80	837,242
C2020	Stair Finishes		0.49	25,893
C3010	Wall Finishes		9.99	529,428
C3020	Floor Finishes		18.36	973,123
C3030	Ceiling Finishes		16.21	859,164
	09 - Finishings		71.60	3,794,850
10	Specialties			
C1010	Partitions		0.65	34,200
C1030	Fittings		4.08	216,500
	10 - Specialties		4.73	250,700
11	Equipment			
E1010	Commercial Equipment		0.91	48,000
E1020	Institutional Equipment		0.40	21,000
E1090	Other Equipment		2.73	144,900
	11 - Equipment		4.04	213,900
12	Furnishings			
E2010	Fixed Furnishings		3.00	159,000
E2020	Movable Furnishings			Excl.
	12 - Furnishings		3.00	159,000
13	Special Construction			
E1090	Other Equipment		36.06	1,911,000
F1030	Special Construction Systems		7.25	384,053
	13 - Special Construction		43.30	2,295,053
14	Conveying Equipment			
D1010	Elevators & Lifts		9.25	490,000
	14 - Conveying Equipment		9.25	490,000
21	Fire Suppression			
D4010	Sprinklers		5.80	307,335
D4030	Fire Protection Specialties		0.15	7,950
D4090	Other Fire Protection Systems		0.58	31,000
	21 - Fire Suppression		6.53	346,285
22	Plumbing			
D2010	Plumbing Fixtures		1.77	94,000

BCYF DORCHESTER
CONCEPT DESIGN COST ESTIMATE - REVISION 2



LOCATION DIVISIONS/ELEMENTS SUMMARY

DR Devine Rink Site (continued)

GFA: 53,000 SF Cost/SF: 643.10
 Rates Current At April 2022

Ref	Description	%	GFA \$/SF	Total Cost \$
D2020	Domestic Water Distribution		6.75	357,750
D2030	Sanitary Waste		11.00	583,000
D2040	Rain Water Drainage		2.00	106,000
D2090	Other Plumbing Systems		2.31	122,449
	22 - Plumbing		23.83	1,263,199
23	Heating, Ventilating, and Air Conditioning			
D3010	Energy Supply		20.88	1,106,730
D3040	Distribution Systems		16.13	855,108
D3050	Terminal & Package Units		21.98	1,164,900
D3060	Controls & Instrumentations		8.00	424,000
D3070	Systems Testing & Balancing		2.00	106,000
D3090	Other HVAC Systems & Equipment		6.91	366,000
	23 - Heating, Ventilating, and Air Conditioning		75.90	4,022,738
26	Electrical			
D5010	Electrical Service & Distribution		14.12	748,100
D5020	Lighting and Branch Wiring		18.96	1,004,728
D5090	Other Electrical Systems		2.45	129,790
G4010	Electrical Distribution		2.92	155,000
G4020	Site Lighting		2.75	145,755
	26 - Electrical		41.20	2,183,373
27	Communications			
D5030	Communications & Security		3.95	209,350
	27 - Communications		3.95	209,350
28	Electronic Safety and Security			
D5030	Communications & Security		5.87	311,110
	28 - Electronic Safety and Security		5.87	311,110
31	Earthwork			
A1010	Standard Foundations		0.55	29,116
A1030	Slab on Grade		0.35	18,713
G1010	Site Clearing		1.49	79,160
G1020	Site Demolition and Relocations		1.04	55,000
G1030	Site Earthwork		0.62	33,000
G1040	Hazardous Waste Remediation			Excl.
	31 - Earthwork		4.06	214,989

BCYF DORCHESTER
CONCEPT DESIGN COST ESTIMATE - REVISION 2



LOCATION DIVISIONS/ELEMENTS SUMMARY

DR Devine Rink Site (continued)

GFA: 53,000 SF Cost/SF: 643.10
 Rates Current At April 2022

Ref	Description	%	GFA \$/SF	Total Cost \$
32	Exterior Improvements			
G2020	Parking Lots		4.18	221,350
G2030	Pedestrian Paving		1.19	63,250
G2040	Site Development		5.48	290,520
G2050	Landscaping		1.32	70,000
	32 - Exterior Improvements		12.17	645,120
33	Utilities			
G3010	Water Supply		1.98	105,000
G3020	Sanitary Water		1.42	75,000
G3030	Storm Sewer		6.98	370,000
	33 - Utilities		10.38	550,000
DEVINE RINK SITE			643.10	34,084,043

BCYF DORCHESTER
CONCEPT DESIGN COST ESTIMATE - REVISION 2



LOCATION DIVISIONS/ELEMENTS SUMMARY

DR Devine Rink Site (continued)

GFA: 53,000 SF Cost/SF: 643.10
 Rates Current At April 2022

Ref	Description	%	GFA \$/SF	Total Cost \$
MARGINS & ADJUSTMENTS				
	General Conditions / Requirements	9.5 %		3,237,985
	Bonds and Insurances	2.8 %		1,026,356
	Overhead and Profit	4.5 %		1,725,678
	Construction Contingency			Excl.
	Design / Estimating Contingency	15.0 %		6,011,109
Subtotal (excl. Escalation)			869.53	46,085,171
	Escalation to Q4 2024	11.0 %		5,069,369
ESTIMATED TOTAL COST			965.18	51,154,540

BCYF DORCHESTER
CONCEPT DESIGN COST ESTIMATE - REVISION 2



LOCATION DIVISIONS/ELEMENTS ITEM

DR Devine Rink Site

GFA: 53,000 SF Cost/SF: 643.10
 Rates Current At April 2022

Ref	Description	Unit	Qty	Rate \$	Total Cost \$
03	CONCRETE				
A1010	Standard Foundations				
59	Cast-in place concrete perimeter strip footing	LF	329.6	100.00	32,960
60	Cast-in place concrete isolated spread footing	EA	36.0	800.00	28,800
317	Cast-in place concrete grade beams, tie-beams, etc	SF	5,260.0	5.00	26,300
	A1010 - Standard Foundations			1.66/SF	88,060
A1020	Special Foundations				
63	Deep foundation systems (assumes not required)	LS	1.0		Excl.
	A1020 - Special Foundations				Excl.
A1030	Slab on Grade				
72	Cast-in-place concrete slab on grade	SF	5,259.6	11.00	57,856
	A1030 - Slab on Grade			1.09/SF	57,856
A2020	Basement Walls				
62	Cast-in place concrete foundation wall	SF	1,153.0	55.00	63,415
76	Cast-in-place elevator pit	EA	2.0	20,000.00	40,000
	A2020 - Basement Walls			1.95/SF	103,415
B1010	Floor Construction				
366	Cast-in-place concrete two-way flat slab (incl. slab, columns, drop-panels, etc)	SF	17,877.0	85.00	1,519,545
77	Cast-in-place concrete topping slab to metal deck	SF	35,125.3	11.00	386,378
84	Premium at first floor pool	SF	7,454.0	40.00	298,160
308	Acoustically isolated slab at elevated Gymnasium	SF	14,346.0	35.00	502,110
	B1010 - Floor Construction			51.06/SF	2,706,193
B1020	Roof Construction				
78	Cast-in-place concrete topping slab to metal deck	SF	20,759.4	11.00	228,353
	B1020 - Roof Construction			4.31/SF	228,353
C1010	Partitions				
79	12" Thick reinforced shear wall (stair/elevator shafts)	SF	8,926.5	60.00	535,590
	C1010 - Partitions			10.11/SF	535,590
C1030	Fittings				
114	Concrete equipment pads, curbs, etc	LS	1.0	5,000.00	5,000
	C1030 - Fittings			0.09/SF	5,000
	03 - CONCRETE			70.27/SF	3,724,467

page not used

BCYF DORCHESTER
CONCEPT DESIGN COST ESTIMATE - REVISION 2



LOCATION DIVISIONS/ELEMENTS ITEM
 DR Devine Rink Site (continued)

GFA: 53,000 SF Cost/SF: 643.10
 Rates Current At April 2022

Ref	Description	Unit	Qty	Rate \$	Total Cost \$
05	METALS				
B1010	Floor Construction				
80	Structural steel floor framing, assumes 15 lbs/SF	T	263.444	5,500.00	1,448,942
361	Isolated steel support at Gym enclosure, assumes 10 lbs/SF	T	74.120	5,500.00	407,660
81	Metal floor deck	SF	35,125.3	8.00	281,002
82	Shear studs	EA	5,854.5	6.00	35,127
83	Miscellaneous steel, plates, and connections	T	26.344	5,500.00	144,892
	B1010 - Floor Construction			43.73/SF	2,317,623
B1020	Roof Construction				
85	Structural steel roof framing, assumes 20 lbs/SF	T	207.594	5,500.00	1,141,767
208	Structural steel rooftop dunnage	LS	1.0	50,000.00	50,000
86	Metal roof deck	SF	5,937.3	8.00	47,498
89	Metal roof deck, acoustic (Gymnasium)	SF	14,822.1	18.00	266,798
87	Shear studs	EA	3,460.0	6.00	20,760
88	Miscellaneous steel, plates, and connections	T	20.760	5,500.00	114,180
	B1020 - Roof Construction			30.96/SF	1,641,003
C1030	Fittings				
115	Painted metal guardrail (egress stairs)	LF	156.0	275.00	42,900
116	Painted metal handrail (egress stairs)	LF	289.7	125.00	36,212
117	Decorative railing system (void, circulation stairs, etc)	LF	104.0	450.00	46,800
223	Structural steel support, operable wall	LF	30.0	350.00	10,500
224	Structural steel support, gymnasium divider	LF	95.0	350.00	33,250
225	Structural steel support, overhead backstops	EA	6.0	6,500.00	39,000
309	Structural steel support, overhead batting cage	EA	1.0	6,500.00	6,500
118	Elevator hoist beam	EA	1.0	5,000.00	5,000
119	Elevator pit ladder	EA	1.0	1,200.00	1,200
120	Elevator sump pit grate and frame	EA	1.0	1,000.00	1,000
121	Miscellaneous metals (MEP supports, casework supports, operable wall support, etc)	SF	53,000.0	3.00	159,000
	C1030 - Fittings			7.20/SF	381,362
C2010	Stair Construction				
209	48" Wide metal pan stair w/- concrete filled treads and landings (egress stair)	FT/R	78.0	2,000.00	156,000

BCYF DORCHESTER
CONCEPT DESIGN COST ESTIMATE - REVISION 2



LOCATION DIVISIONS/ELEMENTS ITEM
 DR Devine Rink Site (continued)

GFA: 53,000 SF Cost/SF: 643.10
 Rates Current At April 2022

Ref	Description	Unit	Qty	Rate \$	Total Cost \$
210	60" Wide decorative circulation stair (Entry)	FT/R	6.0	7,500.00	45,000
	C2010 - Stair Construction			3.79/SF	201,000
	05 - METALS			85.68/SF	4,540,988
06	WOOD, PLASTICS, AND COMPOSITES				
C1030	Fittings				
122	Wood blocking / rough carpentry	SF	53,000.0	2.00	106,000
	C1030 - Fittings			2.00/SF	106,000
E2010	Fixed Furnishings				
189	Built-in casework to Art Room (base cabinet and overheads, closet shelving)	SF	1,573.9	10.00	15,739
190	Built-in casework to Circulation (none)	SF	6,756.1		Excl.
191	Built-in casework to Community Room (kitchenette, storage shelving)	SF	1,194.3	10.00	11,943
192	Built-in casework to Entry (reception desk, built-in benches, shelving, displays, etc)	SF	1,172.9	35.00	41,051
193	Built-in casework to Fitness Room (cubbies, misc. storage)	SF	2,558.2	5.00	12,791
194	Built-in casework to Gymnasium (nutrition station, misc. storage built-ins, etc)	SF	13,850.4	1.00	13,850
195	Built-in casework to Kitchen (base cabinet and overhead, cooking island)	SF	496.6	65.00	32,279
196	Built-in casework to Locker (vanity, changing bench, towel-drop, shower shelf, etc)	SF	2,393.8	15.00	35,907
197	Built-in casework to Makerspace (workstations, printer stations, base cabinets, peg boards)	SF	1,466.2	20.00	29,324
198	Built-in casework to MEP (none)	SF	3,462.9		Excl.
199	Built-in casework to Office (none)	SF	1,045.5		Excl.
200	Built-in casework to Pool (cubbies)	SF	8,331.9	1.50	12,498
201	Built-in casework to Senior Room (closet shelving, kitchenette)	SF	1,212.5	15.00	18,187
202	Built-in casework to Support Spaces (none)	SF	722.1		Excl.
203	Built-in casework to Tech Room (cubbies, wall units)	SF	1,449.4	10.00	14,494
204	Built-in casework to Restrooms (none)	SF	571.1		Excl.
205	Built-in casework to Youth Classroom (closet shelving, base cabinets, cubbies, etc)	SF	1,194.8	25.00	29,870

BCYF DORCHESTER
CONCEPT DESIGN COST ESTIMATE - REVISION 2



LOCATION DIVISIONS/ELEMENTS ITEM
 DR Devine Rink Site (continued)

GFA: 53,000 SF Cost/SF: 643.10
 Rates Current At April 2022

Ref	Description	Unit	Qty	Rate \$	Total Cost \$
206	Built-in casework to Youth Flex Space (base cabinets, cubbies, kitchenette, vanity)	SF	1,190.1	30.00	35,703
	E2010 - Fixed Furnishings			5.73/SF	303,636
	06 - WOOD, PLASTICS, AND COMPOSITES			7.73/SF	409,636
07	THERMAL AND MOISTURE PROTECTION				
A1030	Slab on Grade				
73	Vapor barrier to slab on grade	SF	5,259.6	0.60	3,156
74	Rigid insulation to slab on grade	SF	5,259.6	4.50	23,668
211	Underslab waterproofing	SF	5,259.6		Excl.
	A1030 - Slab on Grade			0.51/SF	26,824
A2020	Basement Walls				
75	Rigid insulation to foundation wall	SF	1,153.0	3.50	4,036
	A2020 - Basement Walls			0.08/SF	4,036
B1010	Floor Construction				
362	Insulation at floor construction above open parking	SF	15,500.0	13.00	201,500
90	Spray-applied fireproofing to structural steel floor framing	SF	53,002.3	4.00	212,009
	B1010 - Floor Construction			7.80/SF	413,509
B1020	Roof Construction				
91	Spray-applied fireproofing to structural steel roof framing	SF	20,759.4	4.50	93,417
	B1020 - Roof Construction			1.76/SF	93,417
B2010	Exterior Walls				
92	Exterior metal wall panel, impact-resistant	SF	22,800.0	100.00	2,280,000
106	Exterior metal soffit panel (exterior parking)	SF	15,500.0	115.00	1,782,500
94	Air and vapor barrier	SF	22,800.0	6.00	136,800
95	Rigid insulation	SF	22,800.0	4.50	102,600
96	Batt insulation	SF	22,800.0	3.00	68,400
212	Exterior caulking and sealing	SF	22,800.0	1.25	28,500
98	Miscellaneous trims and flashings	SF	22,800.0	2.00	45,600
	B2010 - Exterior Walls			83.86/SF	4,444,400
B3010	Roof Coverings				
104	Membrane roofing incl. back-up assembly (insulation, coverboard, etc)	SF	20,759.4	32.00	664,301
363	Premium roofing and pavers at roof deck	SF	2,521.0	65.00	163,865
227	Finish at inside face of parapet	SF	1,730.2	25.00	43,255
226	Parapet cap	LF	692.1	50.00	34,605

BCYF DORCHESTER
CONCEPT DESIGN COST ESTIMATE - REVISION 2



LOCATION DIVISIONS/ELEMENTS ITEM
 DR Devine Rink Site (continued)

GFA: 53,000 SF Cost/SF: 643.10
 Rates Current At April 2022

Ref	Description	Unit	Qty	Rate \$	Total Cost \$
105	Roof walkway pads	SF	1,038.2	15.00	15,573
213	Roof safety fall-arrest system	LS	1.0	25,000.00	25,000
	B3010 - Roof Coverings			17.86/SF	946,599
C1030	Fittings				
123	Firestopping	SF	53,000.0	1.00	53,000
124	Interior caulking and sealing	SF	53,000.0	1.50	79,500
	C1030 - Fittings			2.50/SF	132,500
	07 - THERMAL AND MOISTURE PROTECTION			114.36/SF	6,061,285
08	OPENINGS				
B2010	Exterior Walls				
93	Exterior curtain wall system, triple-glazed, impact-resistant	SF	10,000.0	200.00	2,000,000
	B2010 - Exterior Walls			37.74/SF	2,000,000
B2030	Exterior Doors				
99	Double-leaf glass door, including frame, finish, and hardware	Pair	2.0	12,000.00	24,000
100	Single-leaf glass door, including frame, finish, and hardware	EA	2.0	6,000.00	12,000
101	Double-leaf wood/metal door, including frame, finish, and hardware	Pair	1.0	3,500.00	3,500
102	Single-leaf wood/metal door, including frame, finish, and hardware	EA	3.0	2,000.00	6,000
103	Automatic door operator	EA	2.0	4,000.00	8,000
	B2030 - Exterior Doors			1.01/SF	53,500
C1010	Partitions				
107	Interior storefront, punched windows, etc (GFA measured)	SF	53,000.0	3.00	159,000
	C1010 - Partitions			3.00/SF	159,000
C1020	Interior Doors				
113	Interior doors, frames, and hardware (GFA measured)	SF	53,000.0	3.50	185,500
	C1020 - Interior Doors			3.50/SF	185,500
	08 - OPENINGS			45.25/SF	2,398,000
09	FINISHINGS				
B2010	Exterior Walls				
97	Back-up wall assembly to metal panel (CFMF, sheathing, GWB)	SF	22,800.0	25.00	570,000
	B2010 - Exterior Walls			10.75/SF	570,000

BCYF DORCHESTER
CONCEPT DESIGN COST ESTIMATE - REVISION 2



LOCATION DIVISIONS/ELEMENTS ITEM

DR Devine Rink Site (continued)

GFA: 53,000 SF Cost/SF: 643.10
 Rates Current At April 2022

Ref	Description	Unit	Qty	Rate \$	Total Cost \$
C1010	Partitions				
108	Drywall partition, standard	SF	12,738.8	15.00	191,082
109	Drywall partition, acoustic	SF	8,105.2	25.00	202,630
111	Drywall partition, furred CMU	SF	17,853.0	10.00	178,530
110	Drywall partitions not yet identified (GFA measured)	SF	53,000.0	5.00	265,000
	C1010 - Partitions			15.80/SF	837,242
C2020	Stair Finishes				
132	Resilient flooring to egress stairs	SF	1,190.9	20.00	23,818
133	Decorative flooring to circulation stairs	SF	64.0		Incl.
134	Resilient wall base to egress stairs	LF	415.1	5.00	2,075
135	Decorative wall base to circulation stairs	SF	36.0		Incl.
	C2020 - Stair Finishes			0.49/SF	25,893
C3010	Wall Finishes				
174	Wall finish to Entry (assumes wood wall panel, 80% of wall area)	SF	1,650.6	45.00	74,277
175	Wall finish to Youth Flex Space (assumes wallcovering, 50% of wall area)	SF	705.1	18.00	12,692
176	Wall finish to Community Room (assumes wood wall panel, 50% of wall area)	SF	706.6	45.00	31,797
177	Wall finish to Kitchen (assumes tiled backsplash)	SF	112.0	35.00	3,920
178	Wall finish to Gymnasium (assumes safety wall pads, 96" high)	SF	3,473.8	16.00	55,581
179	Wall finish to Gymnasium (assumes acoustic wall panel, 20% of wall area)	SF	2,330.7	25.00	58,267
180	Wall finish to Locker Rooms (assumes ceramic wall tile, full height)	SF	5,585.5	22.00	122,881
181	Wall finish to Pool (assumes ceramic tile, 96" wainscot)	SF	2,909.7	22.00	64,013
182	Wall finishes not yet identified (GFA measured)	SF	53,000.0	2.00	106,000
	C3010 - Wall Finishes			9.99/SF	529,428
C3020	Floor Finishes				
136	Floor finish to Art Room (assumes heavy duty resilient flooring)	SF	1,573.9	16.00	25,182
137	Floor finish to Circulation (assumes heavy duty resilient flooring)	SF	6,756.1	16.00	108,098
138	Floor finish to Community Room (assumes premium resilient flooring)	SF	1,194.3	18.00	21,497
139	Floor finish to Entry (assumes heavy duty resilient flooring)	SF	1,172.9	16.00	18,766

BCYF DORCHESTER
CONCEPT DESIGN COST ESTIMATE - REVISION 2



LOCATION DIVISIONS/ELEMENTS ITEM

DR Devine Rink Site (continued)

GFA: 53,000 SF Cost/SF: 643.10
 Rates Current At April 2022

Ref	Description	Unit	Qty	Rate \$	Total Cost \$
140	Floor finish to Fitness Room (assumes sports flooring)	SF	2,558.2	20.00	51,164
141	Floor finish to Gymnasium (assumes sports flooring)	SF	13,850.4	20.00	277,008
142	Floor finish to Kitchen (assumes epoxy flooring)	SF	496.6	14.00	6,952
143	Floor finish to Locker (assumes ceramic tile)	SF	2,393.8	22.00	52,664
144	Floor finish to Makerspace (assumes heavy duty resilient flooring)	SF	1,466.2	16.00	23,459
145	Floor finish to MEP (assumes concrete sealer)	SF	3,462.9	2.00	6,926
146	Floor finish to Office (assumes heavy duty resilient flooring)	SF	1,045.5	6.00	6,273
147	Floor finish to Pool (assumes ceramic tile)	SF	5,131.9	22.00	112,902
148	Floor finish to Senior Room (assumes heavy duty resilient flooring)	SF	1,212.5	16.00	19,400
149	Floor finish to Support Spaces (assumes heavy duty resilient flooring)	SF	722.1	16.00	11,554
150	Floor finish to Tech Room (assumes heavy duty resilient flooring)	SF	1,449.4	16.00	23,190
151	Floor finish to Restrooms (assumes ceramic floor tile)	SF	571.1	22.00	12,564
152	Floor finish to Youth Classroom (assumes heavy duty resilient flooring)	SF	1,194.8	16.00	19,117
153	Floor finish to Youth Flex Space (assumes heavy duty resilient flooring)	SF	1,190.1	16.00	19,042
172	Wall bases (GFA measured)	SF	53,000.0	1.00	53,000
173	Moisture mitigation	SF	18,975.3	5.50	104,365
	C3020 - Floor Finishes			18.36/SF	973,123
C3030	Ceiling Finishes				
154	Ceiling finish to Art Room (assumes ACT)	SF	1,573.9	10.00	15,739
155	Ceiling finish to Circulation (assumes ACT)	SF	6,756.1	10.00	67,561
156	Ceiling finish to Community Room (assumes 50% decorative ACT/ 50% painted GWB)	SF	1,194.3	35.00	41,801
157	Ceiling finish to Entry (assumes assumes premium ACT / clouds)	SF	1,172.9	45.00	52,780
158	Ceiling finish to Fitness Room (assumes ACT)	SF	2,558.2	15.00	38,373
159	Ceiling finish to Gymnasium (assumes painted exposed structure)	SF	13,850.4	3.50	48,476
160	Ceiling finish to Kitchen (assumes vinyl-faced ACT)	SF	496.6	14.00	6,952
161	Ceiling finish to Locker (assumes painted GWB)	SF	2,393.8	20.00	47,876
162	Ceiling finish to Makerspace (assumes ACT)	SF	1,466.2	10.00	14,662
163	Ceiling finish to MEP (assumes ACT)	SF	3,462.9	10.00	34,629

BCYF DORCHESTER
CONCEPT DESIGN COST ESTIMATE - REVISION 2



LOCATION DIVISIONS/ELEMENTS ITEM

DR Devine Rink Site (continued)

GFA: 53,000 SF Cost/SF: 643.10
 Rates Current At April 2022

Ref	Description	Unit	Qty	Rate \$	Total Cost \$
164	Ceiling finish to Office (assumes ACT)	SF	1,045.5	10.00	10,455
165	Ceiling finish to Pool (assumes acoustic drywall)	SF	8,331.9	45.00	374,935
166	Ceiling finish to Senior Room (assumes premium ACT)	SF	1,212.5	15.00	18,187
167	Ceiling finish to Support Spaces (assumes ACT)	SF	722.1	10.00	7,221
168	Ceiling finish to Tech Room (assumes ACT)	SF	1,449.4	10.00	14,494
169	Ceiling finish to Restrooms (assumes painted GWB)	SF	571.1	20.00	11,422
170	Ceiling finish to Youth Classroom (assumes ACT)	SF	1,194.8	10.00	11,948
171	Ceiling finish to Youth Flex Space (assumes ACT / clouds)	SF	1,190.1	35.00	41,653
	C3030 - Ceiling Finishes			16.21/SF	859,164
	09 - FINISHINGS			71.60/SF	3,794,850
10	SPECIALTIES				
C1010	Partitions				
112	Operable partition, manually operated (Community Room)	SF	360.0	95.00	34,200
	C1010 - Partitions			0.65/SF	34,200
C1030	Fittings				
125	Lockers, metal standard (2-tier)	EA	70.0	400.00	28,000
126	Restroom accessories; toilet partition cubicle, standard	EA	8.0	1,200.00	9,600
228	Restroom accessories; toilet partition cubicle, ADA	EA	2.0	1,600.00	3,200
229	Restroom accessories; shower partition cubicle, standard	EA	10.0	1,500.00	15,000
230	Restroom accessories; shower partition cubicle, ADA	EA	4.0	2,000.00	8,000
231	Restroom accessories; ADA shower seat	EA	4.0	450.00	1,800
232	Restroom accessories; shower bench	EA	14.0	600.00	8,400
233	Restroom accessories; grab bar set	EA	8.0	250.00	2,000
234	Restroom accessories; toilet roll holder	EA	12.0	150.00	1,800
235	Restroom accessories; paper towel dispenser / receptacle	EA	6.0	450.00	2,700
236	Restroom accessories; electric hand dryer	EA	6.0	800.00	4,800
237	Restroom accessories; soap dispenser	EA	10.0	125.00	1,250
238	Restroom accessories; baby changing station	EA	4.0	600.00	2,400
239	Restroom accessories; robe hook	EA	26.0	50.00	1,300
240	Restroom accessories; shower rod and curtain	EA	14.0	250.00	3,500
241	Restroom accessories; mirror	EA	10.0	450.00	4,500
127	Janitor accessories	LS	1.0	1,000.00	1,000
128	Fire extinguisher and cabinet	EA	10.0	450.00	4,500
129	Corner guards and crash rails	SF	53,000.0	0.25	13,250

BCYF DORCHESTER
CONCEPT DESIGN COST ESTIMATE - REVISION 2



LOCATION DIVISIONS/ELEMENTS ITEM

DR Devine Rink Site (continued)

GFA: 53,000 SF Cost/SF: 643.10
 Rates Current At April 2022

Ref	Description	Unit	Qty	Rate \$	Total Cost \$
242	Markerboards / tackboards	SF	53,000.0	0.50	26,500
130	Interior code and wayfinding signage	SF	53,000.0	1.00	53,000
131	Exterior building signage	LS	1.0	20,000.00	20,000
	C1030 - Fittings			4.08/SF	216,500
	10 - SPECIALTIES			4.73/SF	250,700
11	EQUIPMENT				
E1010	Commercial Equipment				
184	Residential appliance package, kitchenette (undercounter refrigerator, dishwasher, microwave)	EA	3.0	3,500.00	10,500
305	Residential appliance package w/- commercial hood, Community Kitchen (cooktop, oven, dishwasher, microwave, refrigerator)	EA	1.0	30,000.00	30,000
304	Laundry equipment (residential-grade)	LS	1.0	7,500.00	7,500
	E1010 - Commercial Equipment			0.91/SF	48,000
E1020	Institutional Equipment				
185	Projection screen	EA	6.0	3,500.00	21,000
186	Projector (assumes FF&E by Owner)	EA	6.0		Excl.
187	Televisions (assumes FF&E by Owner)	EA	12.0		Excl.
316	3D Printers, laser cutters, fume hoods, etc (assumes by Owner)	LS	1.0		Excl.
	E1020 - Institutional Equipment			0.40/SF	21,000
E1090	Other Equipment				
243	Backstop (retractable, ceiling-mounted)	EA	6.0	10,000.00	60,000
306	Batting cage (retractable, ceiling mounted)	EA	1.0	15,000.00	15,000
307	Volleyball court inserts, sleeves, etc	EA	1.0	5,000.00	5,000
244	Scoreboard	EA	1.0	20,000.00	20,000
246	Shot clock	EA	1.0	5,000.00	5,000
245	Gymnasium divider netting	SF	2,660.0	15.00	39,900
	E1090 - Other Equipment			2.73/SF	144,900
	11 - EQUIPMENT			4.04/SF	213,900
12	FURNISHINGS				
E2010	Fixed Furnishings				
188	Window shades to exterior glazing (assumes 70% manually operated)	SF	7,000.0	12.00	84,000

BCYF DORCHESTER
CONCEPT DESIGN COST ESTIMATE - REVISION 2



LOCATION DIVISIONS/ELEMENTS ITEM

DR Devine Rink Site (continued)

GFA: 53,000 SF Cost/SF: 643.10
 Rates Current At April 2022

Ref	Description	Unit	Qty	Rate \$	Total Cost \$
364	Window shades to exterior glazing (assumes 30% motorized operated)	SF	3,000.0	25.00	75,000
	E2010 - Fixed Furnishings			3.00/SF	159,000
E2020	Movable Furnishings				
220	Loose furniture, fittings, and equipment - FF&E (by Owner)	LS	1.0		Excl.
	E2020 - Movable Furnishings				Excl.
	12 - FURNISHINGS			3.00/SF	159,000
13	SPECIAL CONSTRUCTION				
E1090	Other Equipment				
214	Lap pool and equipment (incl. pumps, chemical treatment system, piping, controls, sporting equipment, rails, starting blocks, finish, etc)	SF	3,822.0	500.00	1,911,000
	E1090 - Other Equipment			36.06/SF	1,911,000
F1030	Special Construction Systems				
216	Precast bleacher	SF	1,383.0	110.00	152,130
217	Structural steel framing to bleacher, assumes 20 lbs/SF	T	13.830	6,500.00	89,895
218	Metal railings to bleacher	LF	237.2	200.00	47,440
219	Aluminum bench seating	LF	540.5	175.00	94,588
	F1030 - Special Construction Systems			7.25/SF	384,053
	13 - SPECIAL CONSTRUCTION			43.30/SF	2,295,053
14	CONVEYING EQUIPMENT				
D1010	Elevators & Lifts				
221	(4) Stop passenger elevator	EA	2.0	225,000.00	450,000
222	Upgraded cab finishes	EA	2.0	20,000.00	40,000
	D1010 - Elevators & Lifts			9.25/SF	490,000
	14 - CONVEYING EQUIPMENT			9.25/SF	490,000
21	FIRE SUPPRESSION				
D4010	Sprinklers				
335	Wet sprinkler system c/w zone control, schedule 40 steel distribution, sprinkler heads, testing etc.	SF	30,818.1	5.25	161,795
336	Dry sprinkler system c/w zone control, schedule 40 steel distribution, sprinkler heads, testing etc.	SF	1,440.0	5.75	8,280
337	Wet sprinkler system c/w zone control, schedule 40 glvanized distribution, sprinkler heads, testing etc. - Pool	SF	8,331.9	6.50	54,158

BCYF DORCHESTER
CONCEPT DESIGN COST ESTIMATE - REVISION 2



LOCATION DIVISIONS/ELEMENTS ITEM

DR Devine Rink Site (continued)

GFA: 53,000 SF Cost/SF: 643.10
 Rates Current At April 2022

Ref	Description	Unit	Qty	Rate \$	Total Cost \$
338	Wet sprinkler system c/w zone control, schedule 40 steel distribution, sprinkler heads, testing etc. - Gym	SF	13,850.4	6.00	83,102
	D4010 - Sprinklers			5.80/SF	307,335
D4030	Fire Protection Specialties				
339	Fire extinguishers	SF	53,000.0	0.15	7,950
	D4030 - Fire Protection Specialties			0.15/SF	7,950
D4090	Other Fire Protection Systems				
340	General Requirements: supervision, shop drawings, as-build drawings, tags, markers, tools, rentals, permits, fees etc.	Item			31,000
	D4090 - Other Fire Protection Systems			0.58/SF	31,000
	21 - FIRE SUPPRESSION			6.53/SF	346,285
22	PLUMBING				
D2010	Plumbing Fixtures				
310	Water closet c/w automatic flush valve	EA	12.0	1,800.00	21,600
311	Lavatory basin c/w automatic faucet	EA	10.0	1,300.00	13,000
312	Shower head and mixing valve, base and enclosure by others.	EA	14.0	800.00	11,200
313	Single compartment sink c/w faucet	EA	5.0	900.00	4,500
314	Mop sink c/w faucet	EA	1.0	1,200.00	1,200
315	Drinking fountain c/w bottle filler	EA	4.0	4,000.00	16,000
346	Miscellaneous fixtures required and not implied: eyewash stations, specialty sinks etc.	SF	53,000.0	0.50	26,500
	D2010 - Plumbing Fixtures			1.77/SF	94,000
D2020	Domestic Water Distribution				
347	Water heating plant c/w equipment, insulated distribution etc.	SF	53,000.0	2.00	106,000
348	Insulated distribution c/w fittings, hangers etc.	SF	53,000.0	3.00	159,000
349	Equipment and plumbing fixture hook-up connections	SF	53,000.0	1.25	66,250
350	Miscellaneous items: trap seal primers system, water hammer arrestors, valves, access doors etc.	SF	53,000.0	0.50	26,500
	D2020 - Domestic Water Distribution			6.75/SF	357,750
D2030	Sanitary Waste				
355	Sanitary drainage system c/w floor drains, clean outs, distribution grease interceptor, excavation bedding and backfill etc.	SF	53,000.0	8.00	424,000
356	Plumbing fixture hookup connections	SF	53,000.0	0.75	39,750

BCYF DORCHESTER
CONCEPT DESIGN COST ESTIMATE - REVISION 2



LOCATION DIVISIONS/ELEMENTS ITEM

DR Devine Rink Site (continued)

GFA: 53,000 SF Cost/SF: 643.10
 Rates Current At April 2022

Ref	Description	Unit	Qty	Rate \$	Total Cost \$
357	Venting	SF	53,000.0	2.25	119,250
358	Pool deck drainage	Note			Incl.
	D2030 - Sanitary Waste			11.00/SF	583,000
D2040	Rain Water Drainage				
352	Storm drainage system c/w roof drains, clean outs, distribution, excavation bedding and backfill etc.	SF	53,000.0	2.00	106,000
	D2040 - Rain Water Drainage			2.00/SF	106,000
D2090	Other Plumbing Systems				
351	General Requirements: supervision, shop drawings, as-build drawings, tags, markers, tools, rentals, permits, fees etc.	Item			115,000
354	Kitchen equipment indirect drain and water hook-up connections	SF	496.6	15.00	7,449
	D2090 - Other Plumbing Systems			2.31/SF	122,449
	22 - PLUMBING			23.83/SF	1,263,199
23	HEATING, VENTILATING, AND AIR CONDITIONING				
D3010	Energy Supply				
1	120 tons Hyper Heat VRF system c/w ducted fan coils , condensing units and BC controllers.	EA	120.0	6,000.00	720,000
320	10 tons Hyper Heat VRF system c/w ducted fan coils , condensing units and BC controllers.	EA	10.0	6,000.00	60,000
319	Insulated refrigerant piping c/w equipment hook-ups	SF	37,100.0	5.00	185,500
328	Refrigerant charge Lbs.	Lb	650.0	25.00	16,250
359	Below pool HVAC system c/w equipment, ductwork system etc.	SF	8,332.0	15.00	124,980
	D3010 - Energy Supply			20.88/SF	1,106,730
D3040	Distribution Systems				
6	Rectangular galvanized ductwork c/w fittings, hangers etc.	Lb	36,718.5	11.00	403,903
7	Thermal insulation	SF	44,668.5	2.25	100,505
8	Aluminum double wall insulated ductwork serving the pool.	LS	1.0	250,000.00	250,000
329	Diffusers and grilles	SF	53,000.0	1.40	74,200
330	Fire dampers, louvers, motorized dampers etc.	SF	53,000.0	0.50	26,500
	D3040 - Distribution Systems			16.13/SF	855,108
D3050	Terminal & Package Units				
3	20,000 cfm pool dehumidification heat-pump	LS	1.0	600,000.00	600,000
5	5,000 cfm ERV- serving the locker rooms	LS	1.0	95,000.00	95,000

BCYF DORCHESTER
CONCEPT DESIGN COST ESTIMATE - REVISION 2



LOCATION DIVISIONS/ELEMENTS ITEM

DR Devine Rink Site (continued)

GFA: 53,000 SF Cost/SF: 643.10
 Rates Current At April 2022

Ref	Description	Unit	Qty	Rate \$	Total Cost \$
9	5,000 cfm heat-pump air handler serving the gym	EA	6.0	60,000.00	360,000
318	4000 cfm MUA serving the kitchen	EA	1.0	30,000.00	30,000
323	4000 cfm exhaust serving the kitchen	LS	1.0	3,000.00	3,000
321	Kitchen 8 foot hood c/w fire suppression system	LS	1.0	10,000.00	10,000
322	Nederman exhaust arms - 650 cfm	No	6.0	3,500.00	21,000
325	4000 cfm exhaust serving the maker space	LS	1.0	30,000.00	30,000
327	Miscellaneous fan coils, FFH, UH's etc	SF	53,000.0	0.30	15,900
	D3050 - Terminal & Package Units			21.98/SF	1,164,900
D3060	Controls & Instrumentations				
331	BAS Controls c/w front end work station, graphics, wiring, devices, testing etc.	SF	53,000.0	8.00	424,000
	D3060 - Controls & Instrumentations			8.00/SF	424,000
D3070	Systems Testing & Balancing				
332	Air Balancing c/w report	SF	53,000.0	0.50	26,500
333	Third party commissioning c/w report	SF	53,000.0	1.50	79,500
	D3070 - Systems Testing & Balancing			2.00/SF	106,000
D3090	Other HVAC Systems & Equipment				
334	General Requirements: supervision, shop drawings, as-build drawings, tags, markers, tools, rentals, permits, fees etc.	Item			366,000
	D3090 - Other HVAC Systems & Equipment			6.91/SF	366,000
	23 - HEATING, VENTILATING, AND AIR CONDITIONING			75.90/SF	4,022,738
26	ELECTRICAL				
D5010	Electrical Service & Distribution				
23	2000A Main switch board, transformers, branch power and lighting panels, feeders	SF	53,000.0	9.00	477,000
21	600kW diesel (including panels, ATS, controls) roof mounted generator-3 story	EA	1.0	221,100.00	221,100
20	Utility transformer backcharge allowance	EA	1.0	50,000.00	50,000
	D5010 - Electrical Service & Distribution			14.12/SF	748,100
D5020	Lighting and Branch Wiring				
24	Mechanical equipment connections	SF	53,000.0	3.62	191,860
26	Entry-Lighting and branch power	SF	1,172.9	11.00	12,902
28	Circulation/Operations-Lighting and branch power	SF	6,756.1	9.00	60,805
29	Community and Education-Lighting and branch power	SF	1,194.3	11.00	13,137

BCYF DORCHESTER
CONCEPT DESIGN COST ESTIMATE - REVISION 2



LOCATION DIVISIONS/ELEMENTS ITEM
 DR Devine Rink Site (continued)

GFA: 53,000 SF Cost/SF: 643.10
 Rates Current At April 2022

Ref	Description	Unit	Qty	Rate \$	Total Cost \$
31	Gym area (double court, fitness, lockers)-Lighting and branch power	SF	13,850.4	20.00	277,008
43	Kitchen area-Lighting and branch power	SF	496.6	21.00	10,429
44	Office area-Lighting and branch power	SF	1,045.5	10.50	10,978
45	Restroom area-Lighting and branch power	SF	571.1	9.25	5,283
46	Stairwell area-Lighting and branch power	SF	1,190.9	8.95	10,659
48	Senior center-Lighting and branch power	SF	1,212.5	12.00	14,550
49	Storage/Support area-Lighting and branch power	SF	722.1	7.60	5,488
50	Pool Mech area-Lighting and branch power	SF	3,462.9	12.00	41,555
51	Fitness area-Lighting and branch power	SF	2,558.2	15.00	38,373
52	Locker area-Lighting and branch power	SF	2,393.8	7.22	17,283
53	Pool area-Lighting and branch power (lighting in pool by others)	SF	8,331.9	23.00	191,634
54	Youth classroom-Lighting and branch power	SF	1,194.8	12.00	14,338
55	Youth Flex area-Lighting and branch power	SF	1,190.1	12.00	14,281
56	Art room area-Lighting and branch power	SF	1,573.9	12.00	18,887
57	Makerspace area-Lighting and branch power	SF	1,466.2	12.00	17,594
58	Tech lab area-Lighting and branch power	SF	1,449.4	26.00	37,684
	D5020 - Lighting and Branch Wiring			18.96/SF	1,004,728
D5090	Other Electrical Systems				
13	Grounding	SF	53,000.0	0.56	29,680
15	AV/Sound system infrastructure only-equipment by others	SF	53,000.0	0.75	39,750
16	PV solar system (conduit and misc. infrastructure only)	LS	1.0	15,000.00	15,000
17	BDA antenna system	LS	1.0	12,500.00	12,500
18	Lightning protection	SF	53,000.0	0.62	32,860
	D5090 - Other Electrical Systems			2.45/SF	129,790
G4010	Electrical Distribution				
41	Primary feeder ductbank underground empty-concrete encased allowance	LF	500.0	115.00	57,500
42	2000A Secondary feeder ductbank encased in concrete-allowance	LF	100.0	975.00	97,500
	G4010 - Electrical Distribution			2.92/SF	155,000
G4020	Site Lighting				
34	Outdoor playground-Lighting and branch power	SF	2,000.0	6.00	12,000
295	Entry Court-Lighting and branch power	SF	2,530.0	6.00	15,180

BCYF DORCHESTER
CONCEPT DESIGN COST ESTIMATE - REVISION 2



LOCATION DIVISIONS/ELEMENTS ITEM
 DR Devine Rink Site (continued)

GFA: 53,000 SF Cost/SF: 643.10
 Rates Current At April 2022

Ref	Description	Unit	Qty	Rate \$	Total Cost \$
47	Exterior parking area-Lighting and branch power-(1) EV station	SF	15,500.0	7.65	118,575
	G4020 - Site Lighting			2.75/SF	145,755
	26 - ELECTRICAL			41.20/SF	2,183,373
27	COMMUNICATIONS				
D5030	Communications & Security				
14	TELECOM infrastructure system including racks, CAT 6 & fiber	SF	53,000.0	3.95	209,350
	D5030 - Communications & Security			3.95/SF	209,350
	27 - COMMUNICATIONS			3.95/SF	209,350
28	ELECTRONIC SAFETY AND SECURITY				
D5030	Communications & Security				
10	Fire Alarm system	SF	53,000.0	4.12	218,360
12	Security system infrastructure including equipment	SF	53,000.0	1.75	92,750
	D5030 - Communications & Security			5.87/SF	311,110
	28 - ELECTRONIC SAFETY AND SECURITY			5.87/SF	311,110
31	EARTHWORK				
A1010	Standard Foundations				
64	Excavation for concrete foundations	CY	376.7	15.00	5,651
65	Remove and dispose of excavated spoils	CY	376.7	30.00	11,301
66	Imported backfill to foundation excavation	CY	87.2	45.00	3,924
71	Sub-soil perimeter drain	LF	329.6	25.00	8,240
	A1010 - Standard Foundations			0.55/SF	29,116
A1030	Slab on Grade				
67	Excavation for new slab on grade	CY	227.4	15.00	3,411
68	Remove and dispose of excavated spoils	CY	227.4	30.00	6,822
69	Imported granular subbase to slab on grade	CY	130.0	45.00	5,850
70	Trim and compact subgrade	SF	5,259.6	0.50	2,630
	A1030 - Slab on Grade			0.35/SF	18,713
G1010	Site Clearing				
247	Site clearing and grubbing	LS	1.0	10,000.00	10,000
291	Temporary site fencing	LF	1,180.0	12.00	14,160
292	Construction entrance, wash-down, etc	LS	1.0	5,000.00	5,000
293	Temporary erosion and sediment control, dust control, etc	LS	1.0	50,000.00	50,000
	G1010 - Site Clearing			1.49/SF	79,160

BCYF DORCHESTER
CONCEPT DESIGN COST ESTIMATE - REVISION 2



LOCATION DIVISIONS/ELEMENTS ITEM

DR Devine Rink Site (continued)

GFA: 53,000 SF Cost/SF: 643.10
 Rates Current At April 2022

Ref	Description	Unit	Qty	Rate \$	Total Cost \$
G1020	Site Demolition and Relocations				
248	Sawcut, break-up, and remove existing asphalt parking lot	SF	33,000.0	1.00	33,000
249	Sawcut, break-up, and remove existing asphalt parking lot (North boundary)	SF	2,000.0	1.00	2,000
250	Miscellaneous site demolition not yet identified	LS	1.0	20,000.00	20,000
	G1020 - Site Demolition and Relocations			1.04/SF	55,000
G1030	Site Earthwork				
252	Site grading, cut and fill	SF	33,000.0	1.00	33,000
253	Excavation in rock (assumes not required)	LS	1.0		Excl.
254	Excavation in contaminated soils (assumes not required)	LS	1.0		Excl.
255	Dewatering (assumes not required)	LS	1.0		Excl.
	G1030 - Site Earthwork			0.62/SF	33,000
G1040	Hazardous Waste Remediation				
251	Hazardous materials abatement (assumes not required)	LS	1.0		Excl.
	G1040 - Hazardous Waste Remediation				Excl.
	31 - EARTHWORK			4.06/SF	214,989
32	EXTERIOR IMPROVEMENTS				
G2020	Parking Lots				
259	Asphalt parking lot (incl. excavation, subgrade, etc)	SY	2,978.0	55.00	163,790
260	Curb	LF	620.0	60.00	37,200
261	Linemarking	SF	26,800.0	0.20	5,360
262	Traffic signage	LS	1.0	5,000.00	5,000
266	Reinstate existing drive entrance	EA	2.0	5,000.00	10,000
	G2020 - Parking Lots			4.18/SF	221,350
G2030	Pedestrian Paving				
263	Decorative unit paver (Entry Court)	SF	2,530.0	25.00	63,250
	G2030 - Pedestrian Paving			1.19/SF	63,250
G2040	Site Development				
265	Benches	EA	2.0	2,000.00	4,000
267	Trash receptacle	EA	2.0	1,500.00	3,000
268	Bike racks	EA	1.0	1,500.00	1,500
269	Bollards	EA	12.0	1,200.00	14,400
270	Site building sign	EA	1.0	15,000.00	15,000
274	Playground equipment	LS	1.0	50,000.00	50,000
275	Playground surfacing	SF	2,521.0	20.00	50,420

BCYF DORCHESTER
CONCEPT DESIGN COST ESTIMATE - REVISION 2



LOCATION DIVISIONS/ELEMENTS ITEM

DR Devine Rink Site (continued)

GFA: 53,000 SF Cost/SF: 643.10
 Rates Current At April 2022

Ref	Description	Unit	Qty	Rate \$	Total Cost \$
276	Privacy/security screen at Third Floor playground	LF	116.0	450.00	52,200
271	Miscellaneous site development not yet identified	LS	1.0	100,000.00	100,000
	G2040 - Site Development			5.48/SF	290,520
G2050	Landscaping				
273	Reinstate surrounding landscaping	LS	1.0	20,000.00	20,000
365	Allowance for plantings at Entry Plaza	LS	1.0	50,000.00	50,000
	G2050 - Landscaping			1.32/SF	70,000
	32 - EXTERIOR IMPROVEMENTS			12.17/SF	645,120
33	UTILITIES				
G3010	Water Supply				
341	Water services c/w street connection, distribution, valves, excavation, bedding and backfill, thrust blocks etc.	LS	1.0	45,000.00	45,000
343	Fire Water services c/w street connection, distribution, valves, excavation, bedding and backfill, thrust blocks etc.	LS	1.0	60,000.00	60,000
	G3010 - Water Supply			1.98/SF	105,000
G3020	Sanitary Water				
342	Sanitary drainage services c/w street connection, distribution, manholes, excavation, bedding and backfill etc. etc.	LS	1.0	75,000.00	75,000
	G3020 - Sanitary Water			1.42/SF	75,000
G3030	Storm Sewer				
344	Storm water drainage system c/w manholes, catch basins, distribution, excavation bedding and backfill etc.	LS	1.0	250,000.00	250,000
345	Storm water retention system - assumed	CF	6,000.0	20.00	120,000
	G3030 - Storm Sewer			6.98/SF	370,000
	33 - UTILITIES			10.38/SF	550,000
	DEVINE RINK SITE			643.10/SF	34,084,043

page not used

Appendix B

Public Engagement

B.1 Public Survey

* Required

1. Are you a Charlestown resident? *

Mark only one oval.

- Yes
- No

2. What is your age range? *

Mark only one oval.

- <20
- 20-29
- 30-39
- 40-49
- 50-59
- 60-69
- >70
- I'd rather not say

3. Which BCYF site in Charlestown do you use most often? *

Mark only one oval.

- BCYF Charlestown and Athletic Center
- BCYF Clougherty Pool and Doherty Playground
- BCYF Golden Age Senior Center
- None of the above

4. If you use a BCYF site what do like best about it?

5. Which community and education programs are most important to you? *

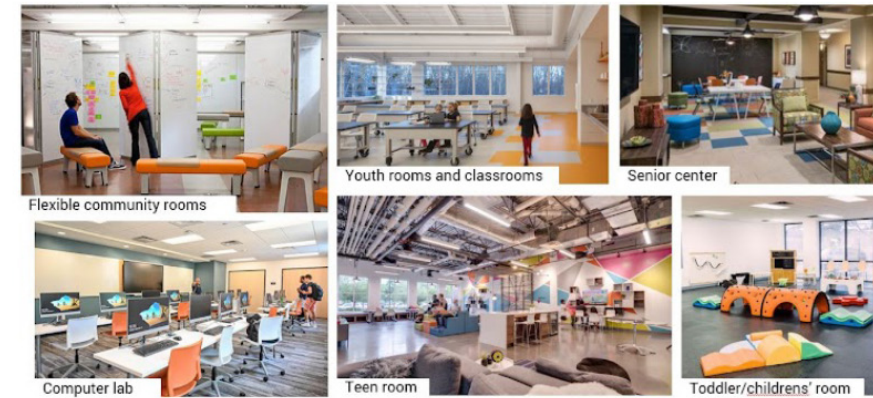

Mark only one oval per row.

	Flexible community rooms	Youth rooms and classrooms	Senior centers	Computer labs	Teen rooms	Toddler/childrens' rooms
First choice	<input type="radio"/>	<input type="radio"/>	<input type="radio"/>	<input type="radio"/>	<input type="radio"/>	<input type="radio"/>
Second choice	<input type="radio"/>	<input type="radio"/>	<input type="radio"/>	<input type="radio"/>	<input type="radio"/>	<input type="radio"/>
Third choice	<input type="radio"/>	<input type="radio"/>	<input type="radio"/>	<input type="radio"/>	<input type="radio"/>	<input type="radio"/>

6. Which art programs are most important to you? *

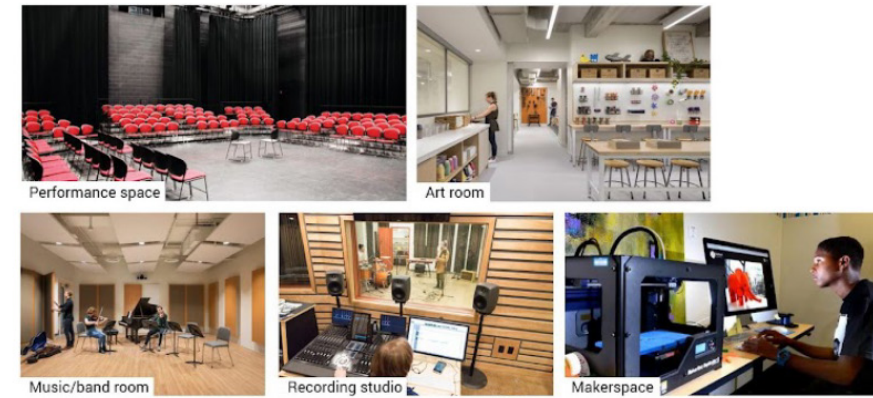

Mark only one oval per row.

	Performance spaces	Art rooms	Music/band rooms	Recording studios	Makerspaces
First choice	<input type="radio"/>	<input type="radio"/>	<input type="radio"/>	<input type="radio"/>	<input type="radio"/>
Second choice	<input type="radio"/>	<input type="radio"/>	<input type="radio"/>	<input type="radio"/>	<input type="radio"/>
Third choice	<input type="radio"/>	<input type="radio"/>	<input type="radio"/>	<input type="radio"/>	<input type="radio"/>

7. What kind of performing arts space works best?



Mark only one oval.

- (1) A medium sized flexible space (a multipurpose space like a community room)
- (2) A large flexible space (a large multipurpose space big enough for a stage and performances)
- (3) A more specialized space (a large space with built in seating like a theatre)
- None of the above. Having a performance arts space is not important to me

8. Which fitness programs are most important to you? *

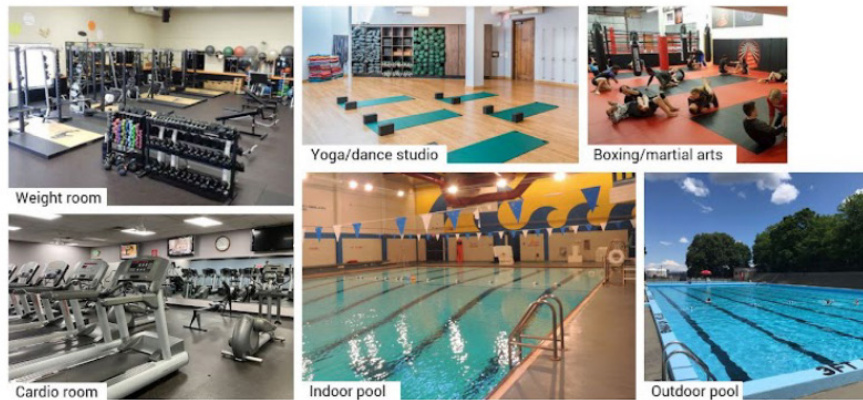

Mark only one oval per row.

	Weight rooms	Yoga/dance studios	Boxing/martial arts	Cardio rooms	Indoor pools	Outdoor pools
First choice	<input type="radio"/>	<input type="radio"/>	<input type="radio"/>	<input type="radio"/>	<input type="radio"/>	<input type="radio"/>
Second choice	<input type="radio"/>	<input type="radio"/>	<input type="radio"/>	<input type="radio"/>	<input type="radio"/>	<input type="radio"/>
Third choice	<input type="radio"/>	<input type="radio"/>	<input type="radio"/>	<input type="radio"/>	<input type="radio"/>	<input type="radio"/>

9. Which gym features are most important to you? *

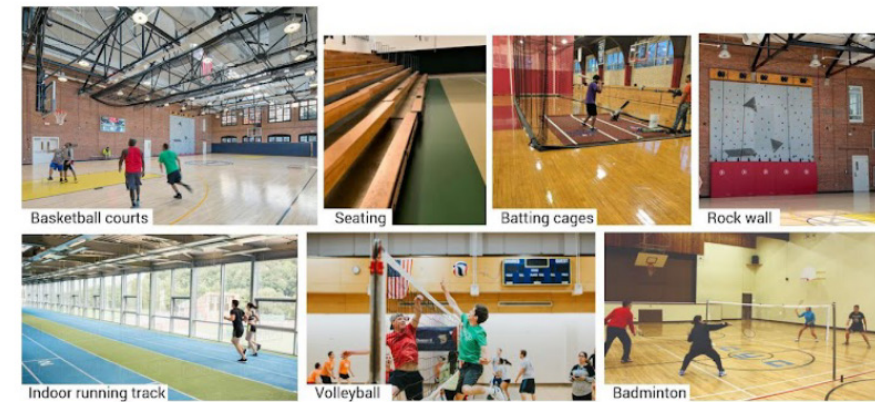

Mark only one oval per row.

	Basketball courts	Spectator seating	Batting cages	Rock wall	Indoor running track	Volleyball	Badminton
First choice	<input type="radio"/>	<input type="radio"/>	<input type="radio"/>	<input type="radio"/>	<input type="radio"/>	<input type="radio"/>	<input type="radio"/>
Second choice	<input type="radio"/>	<input type="radio"/>	<input type="radio"/>	<input type="radio"/>	<input type="radio"/>	<input type="radio"/>	<input type="radio"/>
Third choice	<input type="radio"/>	<input type="radio"/>	<input type="radio"/>	<input type="radio"/>	<input type="radio"/>	<input type="radio"/>	<input type="radio"/>

10. Which outdoor spaces are most important to you? *



Mark only one oval per row.

	Gathering entrance	Playscape	Sports Field	Basketball courts	Outdoor assembly area
First choice	<input type="radio"/>	<input type="radio"/>	<input type="radio"/>	<input type="radio"/>	<input type="radio"/>
Second choice	<input type="radio"/>	<input type="radio"/>	<input type="radio"/>	<input type="radio"/>	<input type="radio"/>
Third choice	<input type="radio"/>	<input type="radio"/>	<input type="radio"/>	<input type="radio"/>	<input type="radio"/>

11. What other programs would you like to see at a new BCYF in Charlestown?

12. Where in Charlestown would you like to see a new BCYF Community Center? Please let us know your site ideas!

13. Email (optional)

Please leave you email address if you would like to receive updates about future community meetings

page not used

B.2 Public Comments

If you use a BCYF site what do you like best about it?

- The pool
- Convenient, great options that are affordable
- Accessibility
- Location
- I would like to access the gym or athletic center (not available now)
- Basketball courts
- Swim Team! Staff, pool and gym facilities
- Outdoor pool! Ability to do laps. Chance to keep fit and exercise.
- Proximity, clean, outdoors
- It's used by young and old alike. A great place to meet with our neighbors. The pool area is special and wonderful. A snack bar is needed and then it will be tops! The park and pudding stone steps are exceptionally beautiful. Movies on the lawn were fantastic. If the fountain were fixed that would be wonderful. The pool is used by everyone. Just a really special place in Charlestown
- Nice range of equipment and friendly staff
- Swim Classes at Pool
- Programs for kids
- Bringing Community together
- In my community, the pool is great in the summer!
- It is low cost activities in our neighborhood. Love being able to stsy bbn in Charlestown and participate with local friends.
- Playground
- It's well maintained
- Options for kids
- Tennis courts
- I love having access to an affordable pool in our neighborhood. My 3 year old loves the splash park at Doherty Playground and my husband uses the basketball court.
- Basketball, space for my daughter (3 yo) to run and scoot around, spray park in the summer, swings/climbing stuff. I'd love to see the pool get renovated. The deep end is always closed. It needs a snack bar.
- Convenience and location to home.
- quality indoor pool and basketball courts
- Location and service
- Pool and swim lessons for my son
- Swim lessons & swim team
- The employees and free/low cost children's programs
- The outdoor space at the BCYF is key for sports; we need more space in charlestown
- Excellent athletic programs with great instructors (swim, basketball)
- The community feel and programs offered.
- The convenient location as well as the great facilities available to the community
- Swim Team and Basketball leagues for my daughters
- The pool and amazing swim instructors!
- The staff and great swim lessons
- WE LOVE the swim team for kids
- BCYF give many options for the community

in Charlestown, in particular for kids and teens

- Program offerings and pricing
- Programs for kids, especially swimming
- The programming is incredible for our children
- Active swimming program
- Childrens activities and swimming lessons. Also summer and school vacation camps for kids.
- The close proximity to our house with multiple sports options and programs.
- The neighborhood feel of everyone coming together.
- the staff is always ready and you feel safe leaving your children. also the swim program is excellent my kids learned and now my grandchildren are using the facility. the best!
- Location is very convenient
- Easy to access, fun to meet new families
- It allows the community to gather and be together.
- convenient location, availability to pool
- Proximity, community at the pool/ playground, low cost
- That everyone in the community can take part, meeting people from the community, variety of programs
- Great staff. Variety of programming. Affordability. Diversity of attendees.
- Accessible space for community members
- open to all ages

What other programs would you like to see at a new BCYF in Charlestown?

- I would love to see more indoor facilities for our youth sports programs so that soccer, lacrosse, softball, baseball, swimming, basketball, and other programs can have more space to practice and offer programming year-round without having to pay to go to facilities outside of the city or share with the High School.
- I would love to see more indoor facilities for our youth sports programs so that soccer, lacrosse, softball, baseball, swimming, basketball, and other programs can have more space to practice and offer programming year-round without having to pay to go to facilities outside of the city or share with the High School
- Indoor tennis
- Gymnastics, youth volleyball and basketball (but not so crowded)
- group exercise classes for all ages, dance classes, art and making classes
- Professional Development - resume writing, interviewing, communications skills
- Splash pad with soft ground, more programs for toddlers to grade school, large community room
- Yoga and meditation classes
- Futsol court and driving range/bays. Food cultivation and cooking classes
- Peer groups, hang outs for high functioning kids w autism. Parent resources. Social connections for parents w kids on the spectrum.

- art classes
- Gardening classes, community showcases, Improved Locker Rooms. Swim Team
- Cooking classes, sewing classes, painting classes, gardening club
- More robust swim program, yoga / pilates / aerobics studio, updated aerobic gym, community space that can be reserved for community meetings, longer hours, improved locker rooms and bathrooms, pickle ball courts, parking for those who may need to drive with young children, Kids (including preschoolers) programs such as Taekwondo, Lego/robotics engineering, dance, none of which are currently offered by schools in Charlestown. Afternoon and weekend programs compatible with working parents (for example, including pick-up from Warren Prescott/ Harvard Kent please!)
- Indoor Turf field like winchester
- More space for sports - CHARLESTOWN youth soccer lacrosse field hockey softball football RSM just built a 2200 sqft makerspace Nutrition/food security/farming
- Karate for kids around 5
- Dance lessons and spaces. Performing arts space and lessons
- More programming at the Community Center. There doesn't seem to be much happening and it's not clear what is happening. Use socialMedia more.
- Tennis, rock climbing, ease of swim lesson access
- Swimming lessons, art classes, book clubs
- Ballet and tap for kids
- Dog park!
- Swimming classes, disc golf (build a small course!), gardening workshops for kids, teens, and adults, indoor mini golf, and if the center is built on the water I would like to see

- community kayaking programs and other water-based activities, community outdoor movie nights
- Community-based programs; skillset building, exercise, group-friendly activities.
- Indoor and outdoor tennis courts, indoor fields similar to Teamworks in Winchester
- drivers ed, first aid, money management, tutoring, etc
- multi-purpose sports fields and courts
- Include multi generational greenspace to enjoy Nature
- Adult fitness classes
- Language classes for kids
- More swim lesson availability
- expansion of swim, golf, tennis
- Art classes, outdoor water spray park
- WE don't have any gymnastics in Charlestown; would love to have that here. Also we don't have boy scouts and would love that.
- Coding, robotics or more STEM programming
- more after school programs for all kids of all ages
- More kids programs like chess club, crafting, maker space, computer clubs
- After school activities such as karate, basketball, swimming - we don't want to lose any of the amazing programs we have had!
- Indoor tennis! Great gym with cardio and nautilus (for younger teens too!), lots of light/ventilation
- Music programming! Theater, dance (groups for just boys too) teens choosing a career or just as extra support. Another program could be tutors for teens who need homework help

B.3 Public Meeting Presentations



Community Meeting 1

November 16, 2020

Recording: <https://www.youtube.com/watch?v=PruZLyI5-Dw>

Community Meeting 2

April 26, 2022

In person

Community Meeting 3

June 14, 2022

Recording: <https://www.youtube.com/watch?v=pIt4617MN8k>

Community Meeting 4

December 08, 2022

In person

